

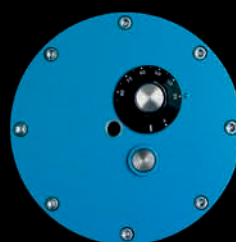

because it works



because it works



ACCESSORIES CATALOGUE

Spray technology • Fluid handling • Material extrusion • Injection

www.wiwa.com

1 WIWA ram presses and single post lifts

- 1.1 WIWA single and twin post ram presses
WIWA holder for ram presses
- 1.2 WIWA mobile ram presses
WIWA single and twin post lifts
WIWA lift trolleys
- 1.3 WIWA follow covers and follow plates
WIWA standard follow covers for 20 – 80 litre (5 – 22 US gal) containers
WIWA follow covers for 216 litre (57 US gal) drums
WIWA optimum purge follow cover for 20 – 60 litres (5 – 16 US gal)
- 1.4 WIWA follow plate for small containers of 20 – 60 litres (5 – 16 US gal)
WIWA follow plate for 216 litre (57 US gal) containers
WIWA optimum purge follow plates for small containers

WIWA single and twin post ram presses

Suitable for precise, clean discharge from original drums and quick drum changes.



Single post ram press with regulator cluster



Twin post ram press (ZSR250)

Order No.	Description	Container, drum size	Compressive or lifting force (N / lbf.ft.)	Travel (mm / inches)
0640604	Single post ram press ESR0375/60 w. regulator cluster	up to 60 l (15.85 US gal) container	3750 / 2765.85	670 / 26.37
0640009	Single post ram press ESR0375/216 w. regulator cluster	up to 216 l (57.06 US gal) drum	3750 / 2765.85	990 / 38.97
0640830	Twin post ram press ZSR030 with regulator cluster	up to 60 l (15.85 US gal) container	3000 / 2212.68	650 / 25.59
0647148	Twin post ram press ZSR075 with regulator cluster	up to 60 l (15.85 US gal) container	7500 / 5531.70	640 / 25.19
0634941	Twin post ram press ZSR075 with regulator cluster	up to 216 l (57.06 US gal) drum	7500 / 5531.70	990 / 38.97
0639338	Twin post ram press ZSR075 with automatic stop function with two-hand operation	up to 216 l (57.06 US gal) drum	7500 / 5531.70	990 / 38.97
0642750	Twin post ram press ZSR250 with regulator cluster	up to 216 l (57.06 US gal) drum	25000 / 18439.02	990 / 38.97
0644724	Twin post ram press ZSR250 with front plate and automatised system	up to 216 l (57.06 US gal) drum	25000 / 18439.02	990 / 38.97

WIWA holder for ram presses

Component of the single and twin post ram presses



Holder for ram press

Order No.	Description
0640978	Complete holder for ram press ZSR075 + ZSR250 for drum model 216 l (57.06 US gal) LM85 and LM105 and LM140
0640964	Complete holder for ram press ZSR075 + ZSR250 for drum model 216 l (57.06 US gal) LM200 and LM230
0640980	Complete holder for ram press ZSR075 + ZSR250 for drum model 216 l (57.06 US gal) LM300 and LM333



Elevating tables for ZSR030; ZSR075 (60 l / 15.85 US gal) and mobile ram presses on request

WIWA mobile ram presses



Mobile ram press with regulator cluster and automatic shut-off

Order No.	Description	Container, drum size	Lifting force (N / lbf.ft.)	Travel (mm / inches)
0640432	Mobile ram press -Lift Model- H030/L-	up to 60 l (15.85 US gal) container	3750 / 2765.85	630 / 24.80
0640882	Mobile ram press Model H030/R-	up to 60 l (15.85 US gal) container	3750 / 2765.85	990 / 38.97
0647510	Mobile ram press Model H075/R-	up to 60 l (15.85 US gal) container	7500 / 5531.70	990 / 38.97
0644756	Mobile ram press Model H250/R-	up to 60 l (15.85 US gal) container	25000 / 18439.02	990 / 38.97

WIWA single and twin post lifts



Single post lift ESR0375/216 with regulator cluster

Order No.	Description	Container/drum size	Lifting force (N / lbf.ft.)	Travel (mm / inches)
0649601	Single post lift	for 60 l (15.85 US gal)	980 / 722.80	630 / 24.80
0648702	Single post lift	for 200 l (52.83 US gal)	980 / 722.80	930 / 36.60
0640604	Single post lift ESR0375/60 with regulator cluster	up to 60 l (15.85 US gal) container	3750 / 2765.85	670 / 26.37
0640009	Single post lift ESR0375/216 with regulator cluster	up to 216 l (57.06 US gal) drum	3750 / 2765.85	990 / 38.97
0634947	Twin post lift ZSR075 with rod fixture for pumps without regulator cluster	up to 216 l (57.06 US gal) drum	7500 / 5531.70	990 / 38.97

WIWA lift trolley



Order No.	Description	Container/drum size	Lifting force (N / lbf.ft.)	Travel (mm / inches)
0648389	Lift trolley	up to 60 l (15.85 US gal) container	620 / 457.28	410 / 16.14

WIWA follow covers and follow plates

For consistent product flow by avoiding the formation of cavities. Also to protect container contents from dust, moisture and hardening on contact with air.

Standard follow cover for 20 – 80 litre (5.28 – 21.13 US gal) containers



Standard follow cover for 30 litre (7.92 US gal) container

Order No.	Description	Container internal diameter (mm / inches)
0642176	Complete follow cover	270 – 305 / 10.62 – 12.00
0646422	Complete follow cover	300 – 330 / 11.81 – 12.99
0646434	Complete follow cover	330 – 360 / 12.99 – 14.17
0646143	Complete follow cover	360 – 385 / 14.17 – 15.15

Follow cover for 216 litre (57.06 US gal) drum



Follow cover for 216 litre (57.06 US gal) containers, standard version

Order No.	Description	Container internal diameter (mm / inches)
0607819	Complete follow cover	570 – 580 / 22.44 – 22.83

Standard follow cover for 20 – 60 litre (5.28 – 15.85 US gal) containers



Complete follow cover for Herkules 275 and 360 (PFP)

Order No.	Description	Container internal diameter (mm / inches)
0647523	Complete follow cover for *Ex 134/120	207 – 232 / 8.14 – 9.13
0647497	Complete follow cover for *Ex 269/120	207 – 232 / 8.14 – 9.13
0647007	Complete follow cover for *Ex 78 + 134/120	270 – 300 / 10.62 – 11.81
0648790	Complete follow cover for Herkules 275 and 360 (PFP)	269 – 285 / 10.59 – 11.22



Follow covers have a lip seal and are suitable for different container diameters and/or for tapered containers. Follow plates have an O-ring seal and are especially designed for one container diameter. Different sealing materials are available on request including NBR, FKM, EPM and silicone.
*Ex = Extrusion pumps

Follow plate for small containers of 20 – 60 litre (5.28 – 15.85 US gal)



Standard follow plate
for small containers up to
355 mm (13.97") diameter

Order No.	Description	Container inside diameter (mm / inches)
0639937	Follow plate, complete for container	280 / 11.02
0641706	Follow plate, complete for container	282 / 11.10
0642469	Follow plate, complete for container	283 / 11.14
0640624	Follow plate, complete for container	285 / 11.22
0640573	Follow plate, complete for container	287 / 11.29
0642905	Follow plate, complete for container	295 / 11.61
0642908	Follow plate, complete for container	300 / 11.81
0639894	Follow plate, complete for container	315 / 12.40
0646900	Follow plate, complete for container	326 / 12.83
0642020	Follow plate, complete for container	328 / 12.91
0642694	Follow plate, complete for container	350 / 13.77
0641616	Follow plate, complete for container	355 / 13.97

Follow plates for 216 litre (57.06 US gal) container



Standard follow plate for 216 litre (57.06 US gal)
drum, Order No. 0644762

Order No.	Description
0644762	Follow plate with 2x cord seals, diameter 42 mm (0.16")
0652157	Follow plate with 2x cord seals, diameter 15 mm (0.06")
0649078	Follow plate, complete with seal, double sealing lip, metal supporting ring and clamping ring
0646505	Electrically heated follow plate, technical data: 1500 W at 230 V

Optimum purge follow plates for small containers

Order No.	Description	Container inside diameter (mm / inch)
0644154	Complete follow plate for Ex 78 + 134/120	280 / 11.02
0643916	Complete follow plate for Ex 78 + 134/120	284 / 11.18
0643896	Complete follow plate for Ex 78 + 134/120	285.7 / 11.24
0644101	Complete follow plate -R- for Ex 78 + 134/120	285 / 11.22
0647530	Complete follow plate -R- for Ex 269/120	328 / 12.91

2 WIWA spray guns and accessories

- 2.1 WIWA spray guns type 250
WIWA spray guns type 500
- 2.2 WIWA spray guns for PFP material
WIWA spray guns type 500F
WIWA Air Combi manual spray guns
- 2.3 WIWA pole guns
WIWA extrusion guns
- 2.4 WIWA Airless automatic spray guns
- 2.5 WIWA Air Combi automatic spray guns
WIWA automatic valves
- 2.7 WIWA tip filters
WIWA filter inserts for Airless spray guns WIWA 250 and 500
WIWA filter inserts for Air Combi spray guns
WIWA tip cleaning needles
- 2.8 WIWA tip guard
WIWA gun extension
WIWA swivel head
- 2.9 WIWA adjustable tip
WIWA reversible guard, Easy Clean
WIWA reversible guard for reversible tip
WIWA tip guard
- 2.10 WIWA mounting kit for reversible Air Combi ball tips
WIWA extrusion tips
- 2.11 WIWA Airless tips
- 2.15 WIWA reversible Air Combi ball tips
- 2.16 WIWA Air Combi tips
- 2.17 WIWA Airless reversible tips
- 2.21 WIWA spray accessory kits for Airless units
with spray guns 250 D / 500 D / 500 F

WIWA spray guns type 250

- suitable for all sprayable media
- for fine paint jobs and large surfaces
- soft two-finger trigger



WIWA 250 D spray gun

Order No.	Model	Description	Max. pressure (bar / psi)
0011258	WIWA 250	Two-finger trigger without swivel 1/4" NPSM with tip connection thread 11/16 UNS	300 / 4350.9
0646997	WIWA 250 D	Two-finger trigger with swivel 1/4" NPSM with tip connection thread 7/8"	300 / 4350.9
0015032	WIWA 250 D	Two-finger trigger with swivel 3/8" NPSM with tip connection thread 11/16 UNS	300 / 4350.9
0632559	WIWA 250 D FI	Two-finger trigger with swivel with tip connection thread 11/16 UNS with M 200 filter in the handle	300 / 4350.9

WIWA spray guns type 500

- soft four-finger trigger
- for work with protective gloves
- can be used with all known Airless systems
- for large surface-area application



WIWA 500 D high-performance spray gun

Order No.	Model	Description	Max. pressure (bar / psi)
0011479	WIWA 500	Four-finger trigger without swivel 1/4" NPSM with tip connection thread 11/16 UNS	500 / 7251.5
0015091	WIWA 500 FI	Four-finger trigger without swivel 1/4" NPSM with tip connection thread 11/16 UNS with M 200 filter in the handle	500 / 7251.5
0015016	WIWA 500 D	Four-finger trigger with swivel 1/4" NPSM with tip connection thread 11/16 UNS	500 / 7251.5
0643409	WIWA 500 D	Four-finger trigger with swivel 1/4" NPSM with tip connection thread 7/8"	500 / 7251.5
0015040	WIWA 500 D	Four-finger trigger with swivel 3/8" NPSM with tip connection thread 11/16 UNS	500 / 7251.5
0015105	WIWA 500 D-FI	Four-finger trigger with swivel 1/4" NPSM with tip connection thread 11/16 UNS with filter M 200 in the handle	500 / 7251.5
0646452	WIWA 500 D-FI	Four-finger trigger with swivel 1/4" NPSM with tip connection thread 7/8" with filter M 200 in the handle	500 / 7251.5

WIWA spray guns for PFP material

- extra large material passages
- ideal for highly viscous materials
- with swivel

Order No.	Model	Description	Max. pressure (bar / psi)
0647352	WIWA 500 FD	Four-finger trigger with front connection with swivel $\frac{1}{2}$ " NPSM with tip connection thread $\frac{7}{8}$ "	500 / 7251.5
0644977	WIWA 500 FD	Four-finger trigger with front connection with swivel $\frac{1}{2}$ " NPSM, tip connection thread $\frac{11}{16}$ " UNS	500 / 7251.5

WIWA spray guns type 500 F

- ideal for hot spraying
- suitable for water-based paints
- non-corroding material path



WIWA 500 F and return flow manifold for hot spraying systems

Order No.	Model	Description	Max. pressure (bar / psi)
0012092	WIWA 500 F	Four-finger trigger with front connection $\frac{1}{4}$ " NPSM with tip connection thread $\frac{11}{16}$ " UNS	500 / 7251.5
0643411	WIWA 500 F	Four-finger trigger with swivel $\frac{1}{4}$ " NPSM with tip connection thread $\frac{7}{8}$ "	500 / 7251.5

WIWA Air Combi Manual spray gun

- air-assisted paint spraying
- low material consumption
- can also be used as an Airless spray gun
- suitable for water-based paints and solvent-based paints



WIWA Air Combi manual spray gun

Order No.	Model	Description	Max. pressure (bar / psi)
0653095	WIWA OPTIMA 2100	Two-finger trigger with front connection $\frac{1}{4}$ " with swivel	250 / 3625.75

WIWA pole guns

Order No.	Description	Max. pressure (bar / psi)
0415456	WIWA pole gun 1.2 m (47.24 inches), ¼" NPSM	200 / 2900.6
0415464	WIWA pole gun 1.8 m (70.86 inches), ¼" NPSM	200 / 2900.6
0415472	WIWA pole gun 2.4 m (94.48 inches), ¼" NPSM	200 / 2900.6

WIWA extrusion guns

For highly viscous materials



Order No.	Description	Max. pressure (bar / psi)
0631299	WIWA extrusion gun without swivel, ⅜" NPTF with tip connection thread 1 ¹ / ₁₆ " UNS	500 / 7251.5

WIWA Air Combi automatic guns



WIWA Air Combi automatic gun

Order No.	Model	Description	Max. pressure (bar / psi)
On request	WIWA Air Combi automatic gun	with tip	200 / 2900.60

WIWA automatic valves



WIWA Air Combi automatic gun

Order No.	Description	Max. pressure (bar / psi)
0632419	WIWA automatic valve, NPSM 1/4", valve needle 4 mm (0.015")	250 / 3625.75
0632232	WIWA automatic valve, G 3/8", valve needle 6 mm (0.02")	400 / 5801.20
0639840	WIWA automatic valve, G 1/2", valve needle 6 mm (0.02")	400 / 5801.20
0646967	WIWA automatic valve, G 1/2", valve needle 10 mm (0.39")	200 / 2900.60
0650580	WIWA automatic valve, G 1/2", valve needle 10 mm (0.39")	400 / 5801.20

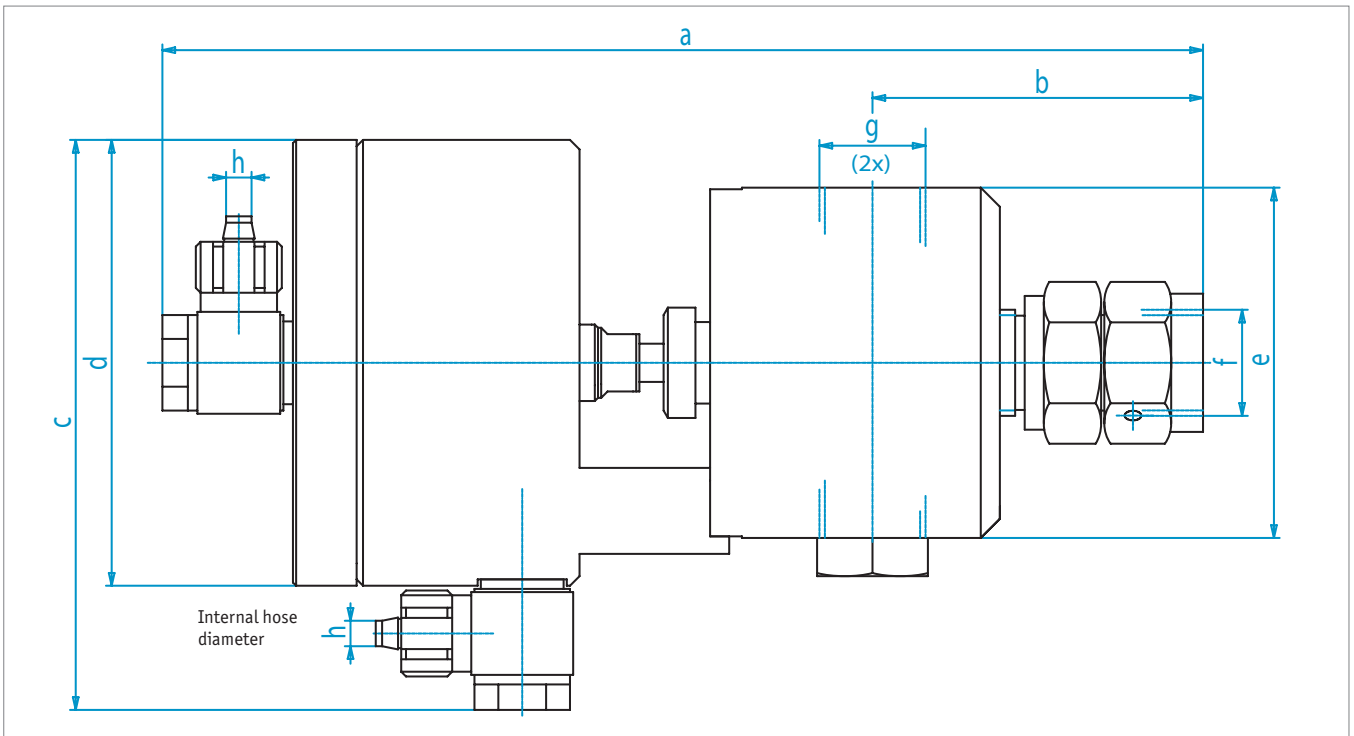

Automatic valve	Dimensions (mm / inches)							
	a	b	c	d	e	f	g	h
0632232	163 / 6.41	52 / 2.040	89.5 / 3.52	70 / 2.75	55 / 2.16	3/8" NPS	G 3/8"	4 / 0.01
0639840	163.5 / 6.43	52 / 2.040	89.5 / 3.52	70 / 2.75	55 / 2.16	3/8" NPS	G 1/2"	4 / 0.01
0646967	174 / 6.85	62.5 / 2.46	89.5 / 3.52	70 / 2.75	60 / 2.36	G 1/2"	G 1/2"	4 / 0.01

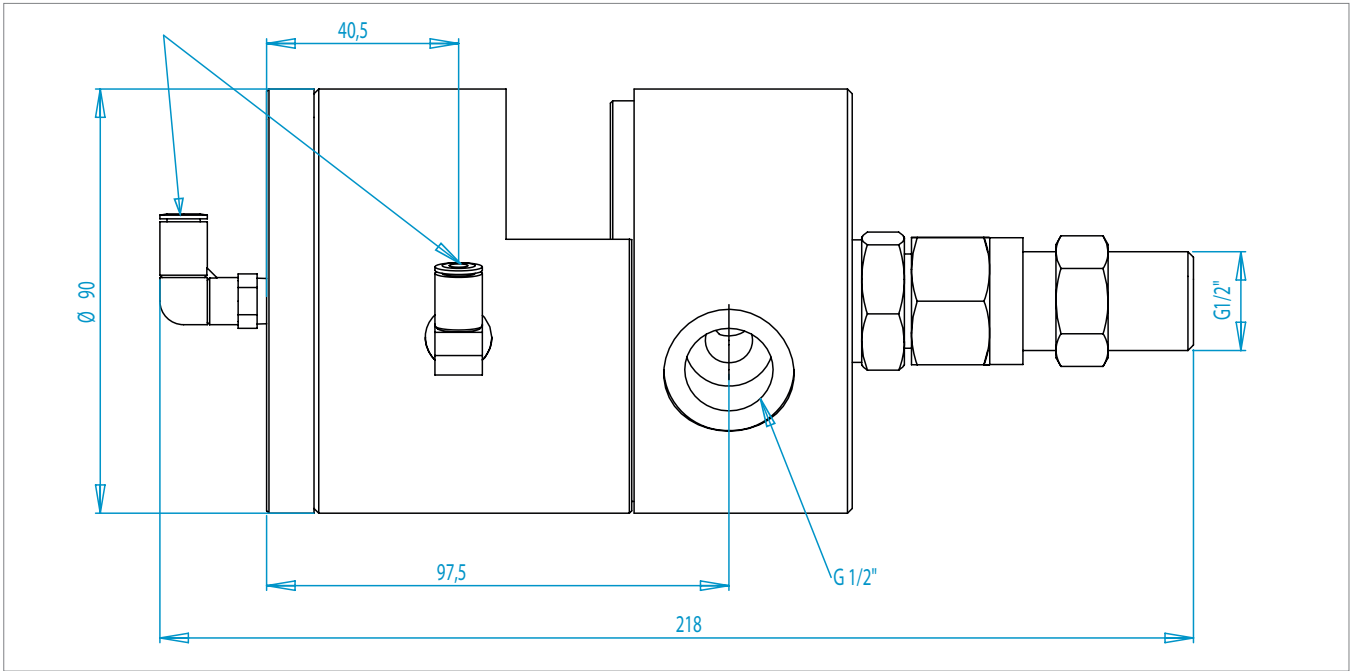

Automatic valve, Order No. 0650580

Tip filter



Tip filter (left) and edge-type filter (right)

Order No.	Description
0638164	Tip filter M 60 complete with housing for Airless spray guns $11/16$ " UNS
0638165	Tip filter M 100 complete with housing for Airless spray guns $11/16$ " UNS
0414433	Edge-type filter M 100, non-corroding, for tip filter M 100
0461520	Edge-type filter M 60, non-corroding, for tip filter M 60

Filter insert for Airless spray guns WIWA 250 and 500



Filter insert for Airless spray guns WIWA 250 and 500

Order No.	Description	Mesh width	Colour
0638201	Filter insert	M 30	Green
0414700	Filter insert	M 50	White
0467448	Filter insert	M 100	Yellow
0638200	Filter insert	M 150	Blue
0467456	Filter insert	M 200	Red

Screw filter for Air Combi spray guns



Screw filter for Air Combi spray guns

Order No.	Description	Mesh width	Colour
0632866	Screw filter	M 50	White
0632867	Screw filter	M 150	Yellow
0632868	Screw filter	M 295	Red

Tip cleaning needles



Tip cleaning needles

Order No.	Description
0627823	Universal tip cleaning needle (x1)
0638229	Universal tip cleaning needle (pack of 12)

Tip guard



Tip guard

Order No.	Description
0638632	Tip guard with swivel nut for Airless spray guns $1\frac{1}{16}$ " UNS V2A
0648808	Tip guard with swivel nut for Airless spray guns $\frac{7}{8}$ "
0468630	Protective tip cap for adjustable tips
084997	Protective tip cap for reversible guard tips

WIWA gun extensions



WIWA gun extension with swivel head

Order No.	Description	Length (cm / inches)	Max. pressure (bar / psi)
0468797	WIWA gun extension, straight	20 / 7.87	400 / 5801.2
0631165	WIWA gun extension, straight, with 90° angled tip	30 / 11.81	350 / 5076.1
0468800	WIWA gun extension, straight	40 / 15.74	400 / 5801.2
0631325	WIWA gun extension, straight	100 / 39.37	400 / 5801.2
0492698	WIWA gun extension, straight	200 / 78.74	400 / 5801.2
0646791	WIWA gun extension with swivel head	10 / 3.93	350 / 5076.1
0646799	WIWA gun extension with swivel head	20 / 7.87	350 / 5076.1
0646800	WIWA gun extension with swivel head	30 / 11.81	350 / 5076.1
0646801	WIWA gun extension with swivel head	40 / 15.74	350 / 5076.1
0646802	WIWA gun extension with swivel head	50 / 19.68	350 / 5076.1

WIWA swivel head



WIWA swivel head

Order No.	Description	Max. pressure (bar / psi)
0465070	WIWA 180° swivel head for spray guns	280 / 4060.84

WIWA adjustable tips



Adjustable tips

Order No.	Code number	Tip opening (mm / inches)	Spray width (mm / inches)	Application
0419052	15	0.07 – 0.18 / 0.003 – 0.007	50 – 400 / 1.97 – 15.75	Paints
0418005	20	0.18 – 0.48 / 0.007 – 0.019	50 – 400 / 1.96 – 15.75	Paints, fillers
0419044	24	0.23 – 0.58 / 0.009 – 0.023	50 – 500 / 1.96 – 19.68	Paints, fillers
0418013	28	0.28 – 0.66 / 0.011 – 0.026	80 – 550 / 3.15 – 21.65	Paints, emulsion paints
0418021	41	0.43 – 0.88 / 0.017 – 0.035	100 – 600 / 3.94 – 23.62	Primers, emulsion paints
0418048	49	0.53 – 1.37 / 0.021 – 0.054	100 – 400 / 3.94 – 15.75	Large surface coating paints

Reversible guards, Easy Clean



Order No.	Description	Max. pressure (bar / psi)
0412244	WIWA "Easy Clean" reversible guard without tip	400 / 5801.2
0622397	WIWA "Easy Clean" reversible guard with tip (60° - 0.66 mm / 0.025")	400 / 5801.2

Reversible guard for reversible tip (see p. 2.11)



Order No.	Description	Max. pressure (bar / psi)
0649204	WIWA reversible guard without tip ¹¹ / ₁₆ " UNS	345 / 5003.5
0649205	WIWA reversible guard without tip ⁷ / ₈ "	345 / 5003.5
0649327	WIWA reversible guard without tip ¹¹ / ₁₆ " UNS	500 / 7251.5
0649328	WIWA reversible guard without tip ⁷ / ₈ "	500 / 7251.5

Mounting kit for ball-type reversing tips Air Combi

Order No.	Description
0642679	Mounting kit for ball-type reversible tips on Air Combi spray guns WIWA Optima 2000 without tip
see table, page 2.15	Ball-type reversible tip for Air Combi spray guns WIWA Optima 2000

Extrusion tips

Order No.	Description
0631129	Extrusion tip type 1.0
0631130	Extrusion tip type 1.5
0631131	Extrusion tip type 2.0
0631132	Extrusion tip type 2.5
0631133	Extrusion tip type 3.0
0631134	Extrusion tip type 3.5
0631135	Extrusion tip type 4.0
0631136	Extrusion tip type 5.0
0631137	Extrusion tip type 6.0
0631138	Extrusion tip type 10.0

WIWA Airless tips

Areas of application	Order No.		Tip openings*				
	Standard tip	Easy Clean tip for reversible guard	mm	inches	Spray angle	Spray width**	
						mm	inches
Clear coat paint Release agents Oils	0416371	–	0.18	0.007	15°	75 – 100	2.95 – 3.94
	–	0417130	0.18	0.007	20°	100 – 125	3.94 – 4.92
	0416215	–	0.18	0.007	25°	125 – 150	4.92 – 5.91
	–	0416975	0.18	0.007	30°	150 – 200	5.91 – 7.87
	0416045	0416819	0.18	0.007	40°	200 – 225	7.87 – 8.86
Clear coat paint Release agents Oils Stains	0416398	–	0.23	0.009	15°	75 – 100	2.95 – 3.94
	–	0417149	0.23	0.009	20°	100 – 125	3.94 – 4.92
	0416223	–	0.23	0.009	25°	125 – 150	4.92 – 5.91
	–	0416983	0.23	0.009	30°	150 – 200	5.91 – 7.87
	0416053	0416827	0.23	0.009	40°	200 – 225	7.87 – 8.86
	–	–	0.23	0.009	50°	225 – 250	8.86 – 9.84
	0418927	0418811	0.23	0.009	60°	250 – 300	9.84 – 11.81
Fine quality paint Transparent paints Release agents Solvent based stains	0416401	–	0.28	0.011	10°	50 – 100	1.97 – 3.94
	0416231	0417157	0.28	0.011	20°	100 – 150	3.94 – 5.91
	–	0416991	0.28	0.011	30°	150 – 200	5.91 – 7.87
	0416061	0416835	0.28	0.011	40°	200 – 250	7.87 – 9.84
	0415901	0416665	0.28	0.011	50°	250 – 300	9.84 – 11.81
	–	0416517	0.28	0.011	60°	300 – 350	11.81 – 13.78
	0415758	–	0.28	0.011	70°	350 – 400	13.78 – 15.75
	0418943	0418846	0.28	0.011	80°	400 – 450	15.75 – 17.72
All types of paint Fillers Water-based paint Thick film varnish	0416428	–	0.33	0.013	10°	50 – 100	1.97 – 3.94
	0416258	0417165	0.33	0.013	20°	100 – 150	3.94 – 5.91
	–	0417009	0.33	0.013	30°	150 – 200	5.91 – 7.87
	0640815	0416843	0.33	0.013	40°	200 – 250	7.87 – 9.84
	0415928	0416673	0.33	0.013	50°	250 – 300	9.84 – 11.81
	0653222	0416525	0.33	0.013	60°	300 – 350	11.81 – 13.78
	0415766	–	0.33	0.013	70°	350 – 400	13.78 – 15.75
	0418951	0418862	0.33	0.013	80°	400 – 450	15.75 – 17.72
All types of paint Primers Zinc chromate primer Fillers Water-based paints Thick film varnish Rust-inhibiting paint	0416266	0465216	0.38	0.015	20°	100 – 150	3.94 – 5.91
	–	0417017	0.38	0.015	30°	150 – 200	5.91 – 7.87
	0416096	0416851	0.38	0.015	40°	200 – 250	7.87 – 9.84
	0415936	0416681	0.38	0.015	50°	250 – 300	9.84 – 11.81
	–	0416533	0.38	0.015	60°	300 – 350	11.81 – 13.78
	0415774	–	0.38	0.015	70°	350 – 400	13.78 – 15.75
	0418978	0418870	0.38	0.015	80°	400 – 450	15.75 – 17.72
All types of paint, primers, fillers, rust-inhibiting paints, zinc primers, zinc dust paints	0416436	–	0.41	0.016	10°	50 – 100	1.97 – 3.94
	–	0417173	0.41	0.016	20°	100 – 150	3.94 – 5.91



The details for spray widths and tip openings are average values and correspond to the usual tolerance for spray tips. When ordering tips, please always state the WIWA order number.

* Other tip sizes available on request ** With an approx. 30 cm (11.81 ") distance from the object

WIWA Airless tips

Areas of application	Order No.		Tip openings*				
	Standard tip	Easy Clean tip for reversible guard	mm	inches	Spray angle	Spray width **	
						mm	inches
All types of paint Primers Fillers Rust-inhibiting paints Zinc primers Zinc dust paints	0642158	–	0.43	0.017	30°	150 – 200	5.91 – 7.87
	0653875	–	0.43	0.017	40°	200 – 250	7.87 – 9.84
	–	–	0.43	0.017	50°	250 – 300	9.84 – 11.81
	0648684	–	0.43	0.017	60°	300 – 350	11.81 – 13.78
	–	–	0.43	0.017	70°	350 – 400	13.78 – 15.75
	0653595	–	0.43	0.017	80°	400 – 450	15.75 – 17.72
	0653596	–	0.43	0.017	90°	450 – 500	17.72 – 19.69
	Primers with a high solids content Fillers Sprayable putty Rust-inhibiting paints Zinc primers Zinc dust paints Epoxy coatings Undercoating	0416274	–	0.46	0.018	20°	100 – 150
–		0417025	0.46	0.018	30°	150 – 200	5.91 – 7.87
0416118		0416878	0.46	0.018	40°	200 – 250	7.87 – 9.84
0415944		0416703	0.46	0.018	50°	250 – 300	9.84 – 11.81
–		0416541	0.46	0.018	60°	300 – 350	11.81 – 13.78
0415782		–	0.46	0.018	70°	350 – 400	13.78 – 15.75
0418986		0418889	0.46	0.018	80°	400 – 450	15.75 – 17.72
0654593		–	0.48	0.019	50°	250 – 300	9.84 – 11.81
0652759		–	0.48	0.019	80°	400 – 450	15.75 – 17.72
0653597		–	0.48	0.019	90°	450 – 500	17.72 – 19.69
Zinc silicates, sprayable putty, antifouling paints, epoxy coatings, latex paints, fillers, emulsion paints, rubber paints, micaceous iron oxide paint, zinc dust paints, undercoating and other rust- inhibiting materials	0416282	0638098	0.53	0.021	20°	100 – 150	3.94 – 5.91
	–	0417033	0.53	0.021	30°	150 – 200	5.91 – 7.87
	0416126	0416886	0.53	0.021	40°	200 – 250	7.87 – 9.84
	0415952	0416711	0.53	0.021	50°	250 – 300	9.84 – 11.81
	0415790	0416568	0.53	0.021	60°	300 – 350	11.81 – 13.78
	0652285	–	0.53	0.021	70°	350 – 400	13.78 – 15.75
	0418994	0418897	0.53	0.021	80°	400 – 450	15.75 – 17.72
	0653598	–	0.53	0.021	90°	450 – 500	17.72 – 19.69
	0652331	–	0.53	0.021	110°	550 – 600	21.65 – 23.62
Epoxy coatings, antifouling paints, emulsion paints, rubber paints, micaceous iron oxide paints, undercoating and other rust-inhibiting materials	0416290	–	0.58	0.023	20°	100 – 150	3.94 – 5.91
	–	0417041	0.58	0.023	30°	150 – 200	5.91 – 7.87
	0416134	0416894	0.58	0.023	40°	200 – 250	7.87 – 9.84
	0415960	0416738	0.58	0.023	50°	250 – 300	9.84 – 11.81
	0653749	0416576	0.58	0.023	60°	300 – 350	11.81 – 13.78
	0415804	–	0.58	0.023	70°	350 – 400	13.78 – 15.75
	0419001	0418900	0.58	0.023	80°	400 – 450	15.75 – 17.72
	0650018	–	0.58	0.023	90°	450 – 500	17.72 – 19.69
	0647718	–	0.58	0.023	110°	550 – 600	21.65 – 23.62



The details for spray widths and tip openings are average values and correspond to the usual tolerance for spray tips. When ordering tips, please always state the WIWA order number.

* Other tip sizes available on request ** With an approx. 30 cm (11.81 ") distance from the object

WIWA Airless tips

Areas of application	Order No.		Tip openings*				
	Standard tip	Easy Clean tip for reversible guard	mm	inches	Spray angle	Spray width**	
						mm	inches
Epoxy coatings Latex paints Antifouling paints Emulsion paints Rubber paints Micaceous iron oxide paint Undercoats and other rust-inhibiting materials	0652137	–	0.63	0.025	60°	300 – 350	11.81 – 13.78
	0651655	–	0.63	0.025	70°	350 – 400	13.78 – 15.75
	0654141	–	0.63	0.025	80°	400 – 450	15.75 – 17.72
	0416304	–	0.66	0.026	20°	100 – 150	3.94 – 5.91
	–	0417068	0.66	0.026	30°	150 – 200	5.91 – 7.87
	0416142	0416908	0.66	0.026	40°	200 – 250	7.87 – 9.84
	0415979	0416746	0.66	0.026	50°	250 – 300	9.84 – 11.81
	–	0416584	0.66	0.026	60°	300 – 350	11.81 – 13.78
	0415812	–	0.66	0.026	70°	350 – 400	13.78 – 15.75
	0419028	0418919	0.66	0.026	80°	400 – 450	15.75 – 17.72
	0650393	–	0.66	0.026	90°	450 – 500	17.72 – 19.69
	0653239	–	0.68	0.027	40°	200 – 250	7.87 – 9.84
	–	–	0.68	0.027	50°	250 – 300	9.84 – 11.81
	0652284	–	0.68	0.027	60°	300 – 350	11.81 – 13.78
	0652286	–	0.68	0.027	70°	350 – 400	13.78 – 15.75
	–	–	0.68	0.027	80°	400 – 450	15.75 – 17.72
	0654140	–	0.68	0.027	90°	450 – 500	17.72 – 19.69
	–	–	0.68	0.027	100°	500 – 550	19.69 – 21.65
	0653246	–	0.68	0.027	110°	550 – 600	21.65 – 23.62
	Glasflake materials Fillers Foundry wash Thick film materials Bitumen Antifouling paints Noise suppressive coatings and other coarsely pigmented coating materials	0653240	–	0.73	0.029	40°	200 – 250
0653245		–	0.73	0.029	110°	550 – 600	21.65 – 23.62
0416312		–	0.78	0.031	20°	100 – 150	3.94 – 5.91
–		0417076	0.78	0.031	30°	150 – 200	5.91 – 7.87
0416150		0416916	0.78	0.031	40°	200 – 250	7.87 – 9.84
0415987		0416754	0.78	0.031	50°	250 – 300	9.84 – 11.81
–		0416592	0.78	0.031	60°	300 – 350	11.81 – 13.78
0415820		–	0.78	0.031	70°	350 – 400	13.78 – 15.75
0415677		0416444	0.78	0.031	80°	400 – 450	15.75 – 17.72
0653223		–	0.84	0.033	80°	400 – 450	15.75 – 17.72
0653224		–	0.84	0.033	90°	450 – 500	17.72 – 19.69



The details for spray widths and tip openings are average values and correspond to the usual tolerance for spray tips. When ordering tips, please always state the WIWA order number.

* Other tip sizes available on request ** With an approx. 30 cm (11.81 ") distance from the object

WIWA Airless tips

Areas of application	Order No.		Tip openings*				
	Standard tip	Easy Clean tip for reversible guard	mm	inches	Spray angle	Spray width**	
						mm	inches
Glasflake materials Fillers Foundry wash Thick film materials Bituminous coal tar pitch and other coarsely pigmented coating materials	0654615	–	0.89	0.035	80°	400 – 450	15.75 – 17.72
	0654614	–	0.89	0.035	90°	450 – 500	17.72 – 19.69
	0416320	–	0.91	0.036	20°	100 – 150	3.94 – 5.91
	–	0417084	0.91	0.036	30°	150 – 200	5.91 – 7.87
	0416169	0416924	0.91	0.036	40°	200 – 250	7.87 – 9.84
	0415995	0416762	0.91	0.036	50°	250 – 300	9.84 – 11.81
	–	0416606	0.91	0.036	60°	300 – 350	11.81 – 13.78
	0415839	–	0.91	0.036	70°	350 – 400	13.78 – 15.75
	0415685	0416452	0.91	0.036	80°	400 – 450	15.75 – 17.72
	0654644	–	0.91	0.036	90°	450 – 500	17.72 – 19.69
	0654616	–	0.94	0.037	80°	400 – 450	5.75 – 17.72
	0416339	–	1.09	0.043	20°	100 – 150	3.94 – 5.91
	–	0417092	1.09	0.043	30°	150 – 200	5.91 – 7.87
	–	0416932	1.09	0.043	40°	200 – 250	7.87 – 9.84
	0416002	0416770	1.09	0.043	50°	250 – 300	9.84 – 11.81
	–	0416614	1.09	0.043	60°	300 – 350	11.81 – 13.78
	0415847	–	1.09	0.043	70°	350 – 400	13.78 – 15.75
	0415693	0416460	1.09	0.043	80°	400 – 450	15.75 – 17.72
	0416347	–	1.35	0.053	20°	100 – 150	3.94 – 5.91
	–	0417106	1.35	0.053	30°	150 – 200	5.91 – 7.87
	0416185	0416940	1.35	0.053	40°	200 – 250	7.87 – 9.84
	0416010	0416789	1.35	0.053	50°	250 – 300	9.84 – 11.81
	–	0416622	1.35	0.053	60°	300 – 350	11.81 – 13.78
	0415855	–	1.35	0.053	70°	350 – 400	13.78 – 15.75
	0415707	0416479	1.35	0.053	80°	400 – 450	15.75 – 17.72
		0417114	1.55	0.061	30°	150 – 200	5.91 – 7.87
	0416193	0416959	1.55	0.061	40°	200 – 250	7.87 – 9.84
	0416029	0416797	1.55	0.061	50°	250 – 300	9.84 – 11.81
		0416630	1.55	0.061	60°	300 – 350	11.81 – 13.78
	0415715		1.55	0.061	80°	400 – 450	15.75 – 17.72
		0417122	1.80	0.072	30°	150 – 200	5.91 – 7.87
	0416207	0416967	1.80	0.072	40°	200 – 250	7.87 – 9.84
	0416037	0416800	1.80	0.072	50°	250 – 300	9.84 – 11.81
	0416649	1.80	0.072	60°	300 – 350	11.81 – 13.78	
0415723	0416495	1.80	0.072	80°	400 – 450	15.75 – 17.72	



The details for spray widths and tip openings are average values and correspond to the usual tolerance for spray tips. When ordering tips, please always state the WIWA order number.

* Other tip sizes available on request ** With an approx. 30 cm (11.81 ") distance from the object

WIWA Air Combi ball-type reversible tips

Areas of application	Order No.	Tip openings*				
		mm	inches	Spray angle	Spray width**	
					mm	inches
General paint work Solvent based paints	0642876	0.23	0.009	30°	150 – 175	5.91 – 6.89
	0642877	0.23	0.009	40°	200 – 250	7.87 – 9.84
	0642878	0.28	0.011	20°	100 – 125	3.94 – 4.92
	0642879	0.28	0.011	30°	150 – 175	5.91 – 6.89
	0642880	0.28	0.011	40°	200 – 250	7.87 – 9.84
	0642881	0.28	0.011	50°	250 – 300	9.84 – 11.81
	0642882	0.28	0.011	60°	300 – 350	11.81 – 13.78
Water-based paints Primers Solvent based paints	0642883	0.33	0.013	20°	100 – 125	3.94 – 4.92
	0642884	0.33	0.013	30°	150 – 175	5.91 – 6.89
	0642885	0.33	0.013	40°	200 – 250	7.87 – 9.84
	0642886	0.33	0.013	50°	250 – 300	9.84 – 11.81
	0642887	0.33	0.013	60°	300 – 350	11.81 – 13.78
Water-based paints Primers Solvent based paints Rust-inhibiting paints	0646317	0.38	0.015	20°	100 – 125	3.94 – 4.92
	0646318	0.38	0.015	30°	150 – 175	5.91 – 6.89
	0646319	0.38	0.015	40°	200 – 250	7.87 – 9.84
	0642888	0.38	0.015	50°	250 – 300	9.84 – 11.81
	0642889	0.38	0.015	60°	300 – 350	11.81 – 13.78
Water-based paints Primers Solvent based paints Rust-inhibiting paints Emulsion paints	0646320	0.43	0.017	50°	250 – 300	9.84 – 11.81
	0646321	0.58	0.023	50°	250 – 300	9.84 – 11.81



The details for spray widths and tip openings are average values and correspond to the usual tolerance for spray tips. When ordering tips, please always state the WIWA order number.

* Other tip sizes available on request ** With an approx. 30 cm (11.81 ") distance from the object

WIWA Air Combi tips

Areas of application	Order No.		Tip openings*				
	for Optima 2000	for Optima 2100	mm	inches	Spray angle	Spray width**	
						mm	inches
General paint work Solvent based paints	0632678	–	0.18	0.007	20°	100 – 125	3.94 – 4.92
	0632679	0653104	0.18	0.007	30°	150 – 175	5.91 – 6.89
	0633867	0653110	0.18	0.007	40°	200 – 250	7.87 – 9.84
	0632680	–	0.23	0.009	10°	50 – 75	1.97 – 2.95
	0632681	0653100	0.23	0.009	20°	100 – 125	3.94 – 4.92
	0632682	0653105	0.23	0.009	30°	150 – 175	5.91 – 6.89
	0632684	–	0.23	0.009	40°	200 – 250	7.87 – 9.84
	0632683	0653117	0.23	0.009	50°	250 – 300	9.84 – 11.81
	0633868	0653121	0.23	0.009	60°	300 – 350	11.81 – 13.78
	0632685	0653101	0.28	0.011	20°	100 – 125	3.94 – 4.92
	0632686	0653106	0.28	0.011	30°	150 – 175	5.91 – 6.89
	0632532	0653111	0.28	0.011	40°	200 – 250	7.87 – 9.84
	0632687	0653118	0.28	0.011	50°	250 – 300	9.84 – 11.81
	0632476	0653122	0.28	0.011	60°	300 – 350	11.81 – 13.78
	Water-based paints Primers Solvent based paints	0632688	0653102	0.33	0.013	20°	100 – 125
0632472		–	0.33	0.013	30°	150 – 175	5.91 – 6.89
0632689		0653112	0.33	0.013	40°	200 – 250	7.87 – 9.84
0632690		0653119	0.33	0.013	50°	250 – 300	9.84 – 11.81
0632468		0653123	0.33	0.013	60°	250 – 300	11.81 – 13.78
Water-based paints Primers Solvent based paints Rust-inhibiting paints	0632691	0653103	0.38	0.015	20°	100 – 125	3.94 – 4.92
	0632692	0653107	0.38	0.015	30°	150 – 175	5.91 – 6.89
	0632693	0653113	0.38	0.015	40°	200 – 250	7.87 – 9.84
	0632694	–	0.38	0.015	50°	250 – 300	9.84 – 11.81
	0632492	0653124	0.38	0.015	60°	300 – 350	11.81 – 13.78
	–	0653108	0.43	0.017	30°	150 – 175	5.91 – 6.89
	–	0653114	0.43	0.017	40°	200 – 250	7.87 – 9.84
	–	0653115	0.46	0.018	40°	200 – 250	9.84 – 11.81
	–	0653125	0.46	0.018	60°	300 – 350	11.81 – 13.78
	0638037	0653116	0.53	0.021	40°	200 – 250	9.84 – 11.81
Water-based paints Primers Solvent based paints Rust-inhibiting paints Emulsion paints	0638038	0653126	0.53	0.021	60°	300 – 350	11.81 – 13.78
	–	0653109	0.58	0.023	30°	150 – 175	5.91 – 6.89



The details for spray widths and tip openings are average values and correspond to the usual tolerance for spray tips. When ordering tips, please always state the WIWA order number.

* Other tip sizes available on request ** With an approx. 30 cm (11.81 ") distance from the object

WIWA Airless reversible tips

Areas of application	Order No.		Tip openings*			
	345 bar / 5003.5 psi	500 bar / 7251.5 psi	Tip designation	mm	inches	Spray angle
Clear coat paints, Release agents, oils, stains	0654137	–	209	0.23	0.009	20°
	0654136	–	309	0.23	0.009	30°
	0649213	0649273	409	0.23	0.009	40°
Fine quality paint Transparent paints Release agents Solvent based stains	0649198	0649261	211	0.28	0.011	20°
	0649208	0649267	311	0.28	0.011	30°
	0649214	0649274	411	0.28	0.011	40°
	0649226	0649288	511	0.28	0.011	50°
	0649238	0649302	611	0.28	0.011	60°
All types of paint Fillers Water-based paints Thick film varnishes	0649199	0649262	213	0.33	0.013	20°
	0649209	0649268	313	0.33	0.013	30°
	0649215	0649275	413	0.33	0.013	40°
	0649227	0649289	513	0.33	0.013	50°
	0649239	0649303	613	0.33	0.013	60°
All types of paint Primers Zinc chromate primers Fillers Water-based paints Thick film varnishes Rust-inhibiting paints	0654491	–	115	0.38	0.015	10°
	0649200	0649263	215	0.38	0.015	20°
	0649192	0649269	315	0.38	0.015	30°
	0649216	0649276	415	0.38	0.015	40°
	0649228	0649290	515	0.38	0.015	50°
	0649240	0649304	615	0.38	0.015	60°
All types of paint Primers Fillers Rust-inhibiting paints Zinc primers Zinc dust paints	0652607	–	117	0.43	0.017	10°
	0649201	0649264	217	0.43	0.017	20°
	0649210	0649270	317	0.43	0.017	30°
	0649194	0649277	417	0.43	0.017	40°
	0649229	0649291	517	0.43	0.017	50°
	0649241	0649305	617	0.43	0.017	60°
	0654291	–	1217	0.43	0.017	120°
Primers with a high solids content Fillers Sprayable putty Rust-inhibiting paints Zinc primers Zinc dust paints Epoxy coatings Undercoating	0649202	0649265	219	0.48	0.019	20°
	0649211	0649271	319	0.48	0.019	30°
	0649217	0649278	419	0.48	0.019	40°
	0649230	0649292	519	0.48	0.019	50°
	0649197	0649306	619	0.48	0.019	60°
	0654292	–	1219	0.48	0.019	120°



The details for spray widths and tip openings are average values and correspond to the usual tolerance for spray tips. When ordering tips, please always state the WIWA order number.

* Other tip sizes available on request

WIWA Airless reversible tips

Areas of application	Order No.		Tip openings*			
	345 bar / 5003.5 psi	500 bar / 7251.5 psi	Tip designation	mm	inches	Spray angle
Zinc silicates, sprayable putty antifouling paints, epoxy coatings, latex paints, fillers, emulsion paints, rubber paints, micaceous iron oxide paint, zinc dust paints, undercoating and other rust-inhibiting materials	0653334	–	121	0.53	0.021	10°
	0654293	–	1221	0.53	0.021	120°
Epoxy coatings, antifouling paints, emulsion paints, rubber paints, micaceous iron oxide paints, undercoating and other rust-inhibiting materials	–	0653792	323	0.58	0.023	30°
	0654294	–	1223	0.58	0.023	120°
	0653284	–	225	0.63	0.025	20°
	–	0653816	325	0.63	0.025	30°
	0653285	–	227	0.68	0.027	20°
	–	0652333	327	0.68	0.027	30°
Glasflake materials, fillers, coating materials, foundry wash, thick film materials, bitumen, antifouling paints, noise suppressive coatings and other coarsely pigmented coating materials	0653325	0653898	329	0.74	0.029	30°
	–	0653256	429	0.74	0.029	40°
	0650001	–	529	0.74	0.029	50°
	–	0652332	629	0.74	0.029	60°
	0652755	–	231	0.78	0.031	20°
	0653326	0653457	331	0.78	0.031	30°
Glasflake materials Fillers Foundry wash Thick film materials Bituminous coal tar pitch and other coarsely pigmented coating materials	0652756	0654648	235	0.89	0.035	20°
	0652191	0652334	335	0.89	0.035	30°
	0652192	–	339	0.99	0.039	30°
	0652757	0654649	241	1.04	0.041	20°
	0652193	0654650	341	1.04	0.041	30°
	0652190	–	343	1.09	0.043	30°
	0649874	–	445	1.14	0.045	40°
	0650377	0653271	247	1.19	0.047	20°
	0650378	–	347	1.19	0.047	30°
	0649875	–	447	1.19	0.047	40°
	0649876	–	449	1.24	0.049	40°
	0653547	–	453	1.35	0.053	40°
	0653272	–	455	1.4	0.055	40°



The details for spray widths and tip openings are average values and correspond to the usual tolerance for spray tips. When ordering tips, please always state the WIWA order number.

* Other tip sizes available on request

WIWA Airless reversible tips

Areas of application	Order No.		Tip openings*			
	345 bar / 5003.5 psi	500 bar / 7251.5 psi	Tip designation	mm	inches	Spray angle
Paints Synthetic resins Oils PVC paint Stains	0649213	0649273	409	0.23	0.007	40°
	0649198	0649261	211	0.28	0.011	20°
	0649208	0649267	311	0.28	0.011	30°
	0649214	0649274	411	0.28	0.011	40°
	0649226	0649288	511	0.28	0.011	50°
	0649238	0649302	611	0.28	0.011	60°
	0649199	0649262	213	0.33	0.013	20°
	0649209	0649268	313	0.33	0.013	30°
	0649215	0649275	413	0.33	0.013	40°
	0649227	0649289	513	0.33	0.013	50°
Fillers Rust-inhibiting paints Acrylic paints Emulsion paints	0649239	0649303	613	0.33	0.013	60°
	0649200	0649263	215	0.38	0.015	20°
	0649192	0649269	315	0.38	0.015	30°
	0649216	0649276	415	0.38	0.015	40°
	0649228	0649290	515	0.38	0.015	50°
	0649240	0649304	615	0.38	0.015	60°
	0649201	0649264	217	0.43	0.017	20°
	0649210	0649270	317	0.43	0.017	30°
	0649194	0649277	417	0.43	0.017	40°
	0649229	0649291	517	0.43	0.017	50°
0649241	0649305	617	0.43	0.017	60°	
0649202	0649265	219	0.48	0.019	20°	
0649211	0649271	319	0.48	0.019	30°	
0649217	0649278	419	0.48	0.019	40°	
0649230	0649292	519	0.48	0.019	50°	
0649197	0649306	619	0.48	0.019	60°	



The details for spray widths and tip openings are average values and correspond to the usual tolerance for spray tips. When ordering tips, please always state the WIWA order number.

* Other tip sizes available on request

WIWA Airless reversible tips

Areas of application	Order No.		Tip openings*				
	345 bar / 5003.5 psi	500 bar / 7251.5 psi	Tip designation	mm	inches	Spray angle	
Primers with a high solids content, fillers, sprayable putty, rust-inhibiting paints, zinc primers, zinc dust paints, epoxy coatings, undercoating	0649203	0649266	221	0.53	0.021	20°	
	0649212	0649272	321	0.53	0.021	30°	
	0649218	0649279	421	0.53	0.021	40°	
	0649195	0649293	521	0.53	0.021	50°	
	0649206	0649307	621	0.53	0.021	60°	
	0649250	0649316	821	0.53	0.021	80°	
Zinc silicates, sprayable putty, antifouling paints, epoxy coatings, latex paints, fillers, emulsion paints, rubber paints, micaceous iron oxide paint, zinc dust paints, undercoating and other rust-inhibiting materials	0649193	0649280	423	0.58	0.023	40°	
	0649231	0649294	523	0.58	0.023	50°	
	0649242	0649308	623	0.58	0.023	60°	
	0649251	0649317	823	0.58	0.023	80°	
Epoxy coatings, antifouling paints, emulsion paints, rubber paints, micaceous iron oxide paints, undercoating and other rust-inhibiting materials	0649219	0649291	425	0.63	0.025	40°	
	0649232	0649295	525	0.63	0.025	50°	
	0649243	0649309	625	0.63	0.025	60°	
	0649252	0649318	825	0.63	0.025	80°	
	0649220	0649282	427	0.68	0.027	40°	
	0649196	0649296	527	0.68	0.027	50°	
	0649244	0649310	627	0.68	0.027	60°	
	0649253	0649319	827	0.68	0.027	80°	
	Glasflake materials, fillers, coating materials, finishing materials, thick film materials, bitumen, antifouling paint, noise suppressive coatings and other coarsely pigmented coating materials	0649221	0649283	431	0.78	0.031	40°
		0649233	0649297	531	0.78	0.031	50°
		0649245	0649311	631	0.78	0.031	60°
		0649254	0649320	831	0.78	0.031	80°
Glasflake materials, fillers, foundry wash, thick film materials, bituminous coal tar pitch and other coarsely pigmented coating materials	0649222	0649284	435	0.89	0.035	40°	
	0649234	0649298	535	0.89	0.035	50°	
	0649246	0649312	635	0.89	0.035	60°	
	0649255	0649321	835	0.89	0.035	80°	
	0649223	0649285	439	0.99	0.039	40°	
	0649235	0649299	539	0.99	0.039	20°	
	0649247	0649313	639	0.99	0.039	30°	
	0649256	0649322	839	0.99	0.039	40°	
	Fillers, bitumen, fibrous coatings and other thick film materials with a high solids content	0649224	0649286	441	1.04	0.041	40°
		0649236	0649300	541	1.04	0.041	50°
0649248		0649314	641	1.04	0.041	60°	
0649257		0649323	841	1.04	0.041	80°	
0649225		0649287	443	1.09	0.043	40°	
0649237		0649301	543	1.09	0.043	50°	
0649249		0649315	643	1.09	0.043	60°	
0649258		0649324	843	1.09	0.043	80°	



The details for spray widths and tip openings are average values and correspond to the usual tolerance for spray tips. When ordering tips, please always state the WIWA order number.

* Other tip sizes available on request

WIWA spraying accessories kit for Airless units

Order No.	No.	Max. pressure (bar / psi)	Hoses 1/4"			with standard tip	with reversible tip
			NW 4 (m / ft)	NW 6 (m / ft)	NW 10 (m / ft)		

with spray gun 250 D / FI / 300

0621625	01	410 / 5946.2	-	7.5 / 24.6	-	40° - 0.33 mm / 0.012"	-
0642474	13	410 / 5946.2	-	7.5 / 24.6	-	40° - 0.28 mm / 0.001"	-

with spray gun 500 D

0621633	02	410 / 5946.2	-	7.5 / 24.6	-	-	60° - 0.027"
0621641	03	600 / 8701.8	-	7.5 / 24.6	-	-	60° - 0.027"
0642475	14	410 / 5946.2	-	7.5 / 24.6	-	-	60° - 0.021"
0642476	15	600 / 8701.8	-	7.5 / 24.6	-	-	60° - 0.021"
0621668	04	410 / 5946.2	-	15 / 49.2	-	-	60° - 0.027"
0621676	05	600 / 8701.8	-	15 / 49.2	-	-	60° - 0.027"

with spray gun 500 F

0621684	06	410 / 5946.2	-	15 / 49.2	-	-	60° - 0.027"
0621935	07	410 / 5946.2	1 / 3.28	7.5 / 24.6	-	40° - 0.53 mm / 0.002"	-
¹⁾ 0629957	10 RS	410 / 5946.2	-	7.5 / 24.6	-	65° - 0.33 mm / 0.001"	-
¹⁾ 0630414	11 RS	410 / 5946.2	1 / 3.28	7.5 / 24.6	-	40° - 0.53 mm / 0.002"	-
0640932	12	500 / 7251.5	-	7.5 / 24.6	15 / 49.21	-	60° - 0.027"
0642477	16	410 / 5946.2	1 / 3.28	7.5 / 24.6	-	65° - 0.53 mm / 0.002"	-
¹⁾ 0642478	17 RS	410 / 5946.2	1 / 3.28	7.5 / 24.6	-	65° - 0.38 mm / 0.001"	-



¹⁾ For all RS type Airless units

D = with swivel

F = with front connection

3 WIWA accessories

- | | |
|---|--|
| <p>3.1 WIWA pneumatic hand-held agitators
WIWA pneumatic agitators
WIWA pneumatic geared agitators</p> <p>3.2 WIWA electric agitators (400 V)
WIWA agitator mounting kit</p> <p>3.3 WIWA material hoses with PA lining
Material hose NW 4 / ID 1/4"
Material hose NW 6 / ID 1/4"
Material hose NW 10 / ID 3/8"</p> <p>3.4 Material hose NW 13 / ID 1/2"
Material hose NW 19 / ID 3/4"</p> <p>3.5 WIWA material hoses with FEP lining
Material hose NW 6 / ID 1/4"
Material hose NW 10 / ID 3/8"
WIWA hose packages for Air Combi</p> <p>3.6 WIWA double nipple (hose connector)
WIWA double nipple (suction line connection)</p> <p>3.7 WIWA connecting nipple</p> <p>3.8 WIWA suction lines
for PROFIT and PHOENIX
for PROFESSIONAL
for HERKULES</p> <p>3.9 WIWA feed hoppers
WIWA bung adaptors for 2" bunghole</p> <p>3.10 WIWA high-pressure filter type 01 for PROFIT
WIWA high-pressure filter type 05 for PHOENIX
WIWA high-pressure filter type 11 for PHOENIX/PROFESSIONAL
WIWA high-pressure filter type 13 for PROFESSIONAL/HERKULES</p> <p>3.11 WIWA high-pressure filter type 13 for PROFESSIONAL/HERKULES
with 3 material outlets
WIWA filter elements for high-pressure filter type 01 and type 05
WIWA filter elements for high-pressure filter type 11 and type 13
WIWA ball valves for high-pressure filters</p> <p>3.12 WIWA suction sieves
WIWA material sieves</p> | <p>3.13 WIWA swivel joints
WIWA L-swivel joints
WIWA Z-swivel joints
WIWA ball valves</p> <p>3.14 WIWA material pressure regulator
WIWA back pressure regulator
WIWA springs for material pressure regulators
for diff. pressures
WIWA rupture discs</p> <p>3.15 WIWA manifolds
WIWA wall brackets</p> <p>3.16 WIWA static mixer, plastic
WIWA accessories for static mixer, plastic
WIWA static mixer
WIWA mixing elements</p> <p>3.17 WIWA air maintenance units
WIWA air pressure regulator</p> <p>3.18 WIWA pressure gauges
WIWA pressure gauge, complete, Ø 63mm (2.48")
WIWA contact pressure gauge 2K</p> |
|---|--|

WIWA agitators

Since coating materials often have a high solids content, agitators are normally required. WIWA offers a wide range of electrically or pneumatically powered agitators to suit all different drums and applications.

Pneumatic manual agitators



Pneumatic manual agitator with gearbox and two counter-rotating agitator shafts, Order No. 0652214

Order No.	Model	Description	Speed (rpm)	Performance (kW / hp)
0064440	HR 30/0.3	Pneumatic manual agitator with agitator shaft for a container up to 30 l (7.92 US gal) contents	500 – 6000	0.3 / 0.41
0064459	HR 200/0.7*	Pneumatic manual agitator with agitator shaft for 216 litres (57.06 US gal) drum	300 – 3000	0.7 / 0.95
0652214	HRG 30/0.65	Pneumatic manual agitator with gearbox and two counter-rotating agitator shafts for containers up to 30 l (7.92 US gal) contents	15 – 150	0.65 / 0.88

Pneumatic agitators

Order No.	Model	Description	Speed (rpm)	Performance (kW / hp)
0647193	R 30/0.06	Pneumatic agitator up to 30 l (7.92 US gal) contents, paddle Ø = 70 mm (2.76")	500 – 3000	0.06 / 0.081
0647194	FD 30/0.06	Pneumatic agitator complete on drum cover, cover Ø = 350 mm (13.78") Agitator shaft length 345 mm (13.58") paddle Ø = 70 mm (2.76")	500 – 3000	0.06 / 0.081
0630657	FD 200/0.7*	Pneumatic agitator without gearbox with agitating propeller, control valve and fog oiler for 216 l (57.06 US gal) drum cover and drum clamp	300 – 3000	0.7 / 0.95

Pneumatic geared agitators



Pneumatic geared agitator with V2A agitator shaft and paddle, Order No. 0644736

Order No.	Model	Description	Speed (rpm)	Performance (kW / hp)
0648537	FDG 30/0.7*	Pneumatic geared agitator with V2A agitator shaft and paddle Ø = 150 mm (5.9") for 30 l (7.92 US gal) drum	7 – 65	0.7 / 0.95
0644736	FDG 200/0.7*	Pneumatic geared agitator with V2A agitator shaft and paddle Ø = 400 mm (15.75") for 216 l (57.06 US gal) drum	22 – 200	0.7 / 0.95
0639950	FDG 200/1.25*	Pneumatic geared agitator, Alu-paddle Ø = 420 mm (16.53") for 216 l (57.06 US gal) drum	22 – 218	1.25 / 1.7

* certified for Zone I acc. to ATEX 94/9/EC (ATEX)

Electrical agitators (400 V)

Order No.	Model	Description	Voltage (V)	Speed (rpm)	Performance (kW / hp)
0641291	FDE 200/0.37	Electrical geared agitator for 216 l (57.06 US gal) drum with triple blade propeller	400	95	0.37 / 0.5
0640646	FDE 1000/0.75	Electrical geared agitator for 1000 l (264.17 US gal) container with triple blade propeller	400	160	0.75 / 1.02

Agitator mounting kits

Order No.	Model	Description	Speed (rpm)	Performance (kW / hp)
0491934	FD 20/0.3*	Pneumatic agitator without gearbox with stirrer basket. For units from the WIWA Airless Profit series (container models)	500 – 6000	0.7 / 0.95
0634416	A200/0.7	Mounting kit for agitator for Airless paint spraying equipment on a cart from the PROFESSIONAL series with holder, control valve, fog oiler and all necessary attachment parts	300 – 3000	0.7 / 0.95
0642709	A200/0.7	Mounting kit for agitator for Airless paint spraying equipment on a cart from the HERKULES series with holder, control valve, fog oiler and all necessary attachment parts	300 – 3000	0.7 / 0.95

Fluid hoses with a PA liner

Fluid hose NW 4 / ID 1/4"



Order No. -N-	Order No. -R-	Length (m / ft)	Connections	Max. operating pressure (bar / psi)
0413429	0630524	1.0 / 3.28	1/4" NPSM	410 / 5946.2
0410845	0630462	7.5 / 24.6	1/4" NPSM	410 / 5946.2
0413852	-	10.0 / 32.8	1/4" NPSM	410 / 5946.2
0413755	-	15.0 / 49.21	1/4" NPSM	410 / 5946.2

Fluid hose NW 6 / ID 1/4"



Order No. -N-	Order No. -R-	Length (m / ft)	Connections	Max. operating pressure (bar / psi)
0163120	0633325	1.0 / 3.28	1/4" NPSM	410 / 5946.2
0621692	0638045	5.0 / 16.4	1/4" NPSM	410 / 5946.2
0410780	0613819	7.5 / 24.6	1/4" NPSM	410 / 5946.2
0413860	0640466	10.0 / 32.8	1/4" NPSM	410 / 5946.2
0413763	0632657	15.0 / 49.2	1/4" NPSM	410 / 5946.2
0467790	-	20.0 / 65.6	1/4" NPSM	410 / 5946.2
0467804	0640989	30.0 / 98.4	1/4" NPSM	410 / 5946.2
0643091	-	5.0 / 16.4	1/4" NPSM	600 / 8701.8
0410802	0632656	7.5 / 24.6	1/4" NPSM	600 / 8701.8
0413879	-	10.0 / 32.8	1/4" NPSM	600 / 8701.8
0413771	0632658	15.0 / 49.2	1/4" NPSM	600 / 8701.8
0634864	-	20.0 / 65.6	1/4" NPSM	600 / 8701.8
0640956	0640957	30.0 / 98.4	1/4" NPSM	600 / 8701.8

Fluid hose NW 10 / ID 3/8"



Order No. -N-	Order No. -R-	Length (m / ft)	Connections	Max. operating pressure (bar / psi)
0647240	-	5.0 / 16.4	3/8" NPSM	330 / 4786
0410810	0632659	7.5 / 24.6	3/8" NPSM	330 / 4786
0413887	-	10.0 / 32.8	3/8" NPSM	330 / 4786
0413798	0632661	15.0 / 49.2	3/8" NPSM	330 / 4786
0639013	-	20.0 / 65.6	3/8" NPSM	330 / 4786
0640966	0640990	30.0 / 98.4	3/8" NPSM	330 / 4786
0621706	0640991	50.0 / 164.04	3/8" NPSM	330 / 4786
0640113	-	5.0 / 16.4	3/8" NPSM	500 / 7251.5
0467847	0632660-	7.5 / 24.6	3/8" NPSM	500 / 7251.5
0640115	0638112	10.0 / 32.8	3/8" NPSM	500 / 7251.5
0467839	0632662	15.0 / 49.2	3/8" NPSM	500 / 7251.5
0467820	-	20.0 / 65.6	3/8" NPSM	500 / 7251.5
0467812	0640959	30.0 / 98.4	3/8" NPSM	500 / 7251.5
0640960	0640961	50.0 / 164.04	3/8" NPSM	500 / 7251.5

Fluid hose NW 13 / ID 1/2"



Order No. -N-	Order No. -R-	Length (m / ft)	Connections	Max. operating pressure (bar / psi)
0634957	-	1.0 / 3.28	1/2" NPSM	470 / 6816.4
0642701	-	5.0 / 16.4	1/2" NPSM	470 / 6816.4
0628967	-	10.0 / 32.8	1/2" NPSM	470 / 6816.4
0499862	-	15.0 / 49.2	1/2" NPSM	470 / 6816.4
0629720	-	20.0 / 65.6	1/2" NPSM	470 / 6816.4
0646239	-	5.0 / 16.4	1/2" NPSM	600 / 8701.8
0644993	-	7.5 / 24.6	1/2" NPSM	600 / 8701.8
0644994	-	10.0 / 32.8	1/2" NPSM	600 / 8701.8
0644995	-	15.0 / 49.2	1/2" NPSM	600 / 8701.8
0644996	-	20.0 / 65.6	1/2" NPSM	600 / 8701.8
0644997	-	25.0 / 82.0	1/2" NPSM	600 / 8701.8
0644992	-	30.0 / 98.4	1/2" NPSM	600 / 8701.8

Fluid hose NW 19 / ID 3/4"

Order No. -N-	Order No. -R-	Length (m / ft)	Connections	Max. operating pressure (bar / psi)
0647102	-	5 / 16.4	3/4" NPSM	460 / 6671.3
0647104	-	7.5 / 24.6	3/4" NPSM	460 / 6671.3
0647103	-	10 / 32.8	3/4" NPSM	460 / 6671.3
0647101	-	15 / 49.2	3/4" NPSM	460 / 6671.3
0647105	-	20 / 65.6	3/4" NPSM	460 / 6671.3

Fluid hoses with FEP liner (used with materials that react with moisture, e.g. isocyanate)

Fluid hose NW 6 / ID ¼"

Order No. -N-	Order No. -R-	Length (m / ft)	Connections	Max. operating pressure (bar / psi)
0641770	-	0.4 / 1.31	¼" NPSM	600 / 8701.8
0641771	-	1.0 / 3.28	¼" NPSM	600 / 8701.8
0641772	-	2.4 / 7.87	¼" NPSM	600 / 8701.8
0641777	-	5.0 / 16.4	¼" NPSM	600 / 8701.8
0640970	0650746	7.5 / 24.6	¼" NPSM	600 / 8701.8
0640971	-	15 / 49.2	¼" NPSM	600 / 8701.8

Fluid hose NW 10 / ID ¾"

Order No. -N-	Order No. -R-	Length (m / ft)	Connections	Max. operating pressure (bar / psi)
0641773	-	0.3 / 0.98	¾" NPSM	500 / 7251.5
0641774	-	0.5 / 1.64	¾" NPSM	500 / 7251.5
0648264	-	0.75 / 2.46	¾" NPSM	500 / 7251.5
0651226	-	1.0 / 3.28	¾" NPSM	500 / 7251.5
0641776	-	1.15 / 3.77	¾" NPSM	500 / 7251.5
0650003	-	7.5 / 24.6	¾" NPSM	500 / 7251.5
0640973	-	15.0 / 49.2	¾" NPSM	500 / 7251.5

Hose packages for Air Combi

Order No. -N-	Order No. -R-	Length (m / ft)	Description	Max. operating pressure (bar / psi)
0641011	0640585	7.5 / 24.6	NW6/NW4; ¼" NPSM, G ¼"	300 / 4350.9
0634891	0634980	7.5 / 24.6	NW6/NW6; ¼" NPSM, G ¼"	300 / 4350.9
0647238	0647251	10 / 32.8	NW6/NW6; ¼" NPSM, G ¼"	300 / 4350.9
0647252	0641120	15 / 49.2	NW6/NW6; ¼" NPSM, G ¼"	300 / 4350.9
-	0653731	7.5 / 24.6	highly flexible, NW6/NW5, ¼" NPSM, G ¼"	250 / 3625.7
-	0653733	7.5 / 24.6	highly flexible, NW6/NW6, ¼" NPSM, G ¼"	250 / 3625.7
-	0653732	15 / 49.2	highly flexible, NW6/NW5, ¼" NPSM, G ¼"	250 / 3625.7
-	0653734	15 / 49.2	highly flexible, NW6/NW6, ¼" NPSM, G ¼"	250 / 3625.7

Connecting nipples

Male adapters (hose coupling)



Order No. -N-	Order No. -R-	Connections		Max. operating pressure (bar / psi)
0484962	0212695	1/4" NPT	1/4" NPT	500 / 7251.5
0484970	0219096	3/8" NPT	3/8" NPT	500 / 7251.5
-	0472883	G 1/2"	G 1/2"	500 / 7251.5
-	0472913	G 3/4"	G 3/4"	500 / 7251.5
0484989	0216003	3/8" NPT	1/4" NPT	500 / 7251.5
0605913	-	1/2" NPT	3/8" NPT	500 / 7251.5
-	0472891	G 3/4"	G 1/2"	500 / 7251.5

Male adapters (suction system connection)



Order No. -N-	Order No. -R-	Connections		for
-	0216100	M25x1	G 1/2"	PROFIT, PHOENIX
-	0215236	M25x1	G 3/4"	PROFIT, PHOENIX
-	0219576	M25x1	G 1"	PROFIT, PHOENIX
-	0221422	M35x1.5	G 1"	SUPER PLUS
-	0618039	M42x1	G 1"	SUPER STAR
-	0649932	M54x1.5	G 3/4"	PROFESSIONAL, HERKULES
-	0640071	M54x1.5	G 1"	PROFESSIONAL, HERKULES
-	0648303	M54x1.5	G 1 1/4"	PROFESSIONAL, HERKULES
-	0639223	M54x1.5	G 1 1/2"	PROFESSIONAL, HERKULES

WIWA connecting nipple



Order No. -N-	Order No. -R-	Connections		Max. operating pressure (bar / psi)
		Swivel nut	Nipple	
-	0630985	1/4" NPSM	G 1/4"	500 / 7251.5
0160172	0160202	3/8" NPSM	G 1/4"	500 / 7251.5
-	0161179	3/8" NPSM	1/4" NPT	500 / 7251.5
0640678	0644965	3/8" NPSM	G 3/8"	500 / 7251.5
-	0642826	3/8" NPSM	3/8" NPT	500 / 7251.5
0631745	-	G 1/2"	3/8" NPSM	500 / 7251.5
0647392	0600962	G 1/2"	G 1/2"	500 / 7251.5
0633712	-	G 3/4"	G 1/2"	500 / 7251.5
0646221	0160695	G 3/4"	G 3/4"	500 / 7251.5
-	0160229	M22x1.5	G 1/4"	500 / 7251.5
-	0630784	M22x1.5	1/4" NPS	500 / 7251.5
-	0162728	M22x1.5	G 3/8"	500 / 7251.5

WIWA suction lines



WIWA suction line, Order No. 0498173



WIWA suction line, Order No. 0652414



WIWA suction line, Order No. 0652416

Order No. -R-	Order No. -RS-	Description
------------------	-------------------	-------------

for PROFIT and PHOENIX

0498173	0627401	Suction line NW13, sieve Ø 70 mm (2.75")
0498181	0627434	Suction line NW20, sieve Ø 150 mm (5.9")
-	0629960	Suction line NW20, sieve Ø 70mm (2.75")
0643900	0643901	Suction line NW20 - 216 l (57.06 US gal) drum, sieve Ø 70mm (2.75")

for PROFESSIONAL

-	0652414	Suction line NW25 with sieve
-	0652416	Suction line NW32 with sieve
-	0652415	Suction line NW25 - 216 l (57.06 US gal) drum with sieve
-	0652417	Suction line NW32 - 216 l (57.06 US gal) drum with sieve

for HERKULES

-	0652416	Suction line NW32 with sieve
-	0652417	Suction line NW32 - 216 l (57.06 US gal) drum with sieve



Hoppers



Hopper with cover, Order No. 0645575

Order No.	Description
0645575	Hopper with cover, PE 1.5 l (0.4 US gal) volume
0645576	Hopper with cover, PE 4.8 l (1.27 US gal) volume
0631064	Hopper with cover, PE complete with sieve M20, 6 l (1.58 US gal) volume



Hopper with cover, Order No. 0631064

Bung adaptors for 2" bunghole



Bung adaptor, alu, Order No. 0490776



Bung adaptor, steel, Order No. 0466102

Order No.	Description	Internal Ø (mm / inches)	for
0471828	Bung adapter, alu	25 / 0.98	
0490776	Bung adapter, alu	28 / 1.1	
0638807	Bung adapter, alu	34 / 1.34	
0471844	Bung adapter, alu	40 / 1.57	
0646523	Bung adaptor, steel	40 / 1.57	RAPID 100.02 R
0210110	Bung adapter, alu	42 / 1.65	
0646999	Bung adapter, alu	45 / 1.77	PROFIT
0646102	Bung adaptor, steel	54 / 2.13	NDP 150 N+R RAPID 200.01 R
0646986	Bung adaptor, steel	55 / 2.16	RAPID 200.01 R

WIWA high-pressure filter

High-pressure filter type 01 for PROFIT Versions N and R with drain valve (version RS with drain screw) material outlet 1/4" NPS and material inlet 3/8" NPSM



WIWA HP filter, Order No. 0060178

Order No.	Description
0060275	Version N
0060178	Version R
0634509	Version RS

High-pressure filter type 05 for PHOENIX with drain valve, material outlet 1/4" NPS and material inlet M 22 x 1.5

Order No.	Description
0060313	Version N
0060216	Version R
0612685	Version RS

High-pressure filter type 11 for PHOENIX / PROFESSIONAL with drain valve, drain hose, 2x material outlets 3/8" NPS, of which 1x reduced to 1/4" NPS, material inlet M 22 x 1.5



WIWA HP filter, Order No. 0011800

Order No.	Description
0621773	Version N
0011800	Version R
0629512	Version RS

High-pressure filter type 13 for PROFESSIONAL / HERKULES with drain valve, drain hose, material inlet R 1" (f), 2x material outlets 3/8" NPS, of which 1x reduced to 1/4" NPS



WIWA HP filter, Order No. 0065285

Order No.	Description
0065285	Version R

i N = nornal steel R = non-corroding RS = rust and acid proof

High-pressure filter type 13 with 3 material outlets for PROFESSIONAL / HERKULES

with drain valve, drain hose, material inlet R 1" (f)
2x material outlets $\frac{3}{8}$ " NPS, 1x material outlet $\frac{1}{4}$ " NPS
can be changed to $\frac{3}{8}$ " or $\frac{1}{2}$ "

Order No.	Description
0643505	Version R (non-corroding)

WIWA filter inserts

Material: Stainless steel mesh, plastic socket

Filter inserts for high-pressure filter type 01 and type 05



Order No.	Mesh	Colour
0463779	M 40	blue
0163023	M 50	orange
0160601	M 70	yellow
0160059	M 100	black
0160628	M 150	red
0160636	M 200	white

Filter inserts for high-pressure filter type 11 and type 13



Order No.	Mesh	Colour
0646628	M 20	green
0467782	M 30	blue
0162787	M 50	orange
0162779	M 70	yellow
0162760	M 100	black
0162752	M 150	red
0162744	M 200	white

Ball valves for high-pressure filters



Order No.	Description	N/R/RS	Connecting thread
0646987	Ball valve for high-pressure filters suitable for type 01 and type 05	N	G $\frac{1}{4}$ " (m/f)
0646988	Ball valve for high-pressure filters suitable for type 11 and type 13	N	G $\frac{1}{4}$ " (f)
0647195	Ball valve for high-pressure filters suitable for types 01, 05, 11 and 13	RS	G $\frac{1}{4}$ " (f)

WIWA suction strainers

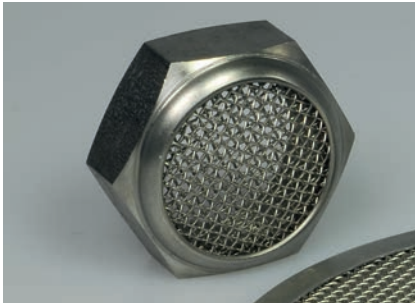

Order No.	Description
0479101	Suction strainer for bunghole approx. 35 mm (1.37") diameter Version RS (rust and acid proof) M25x1/M30 for all units from the PROFIT and PHOENIX series
0643547	Suction strainer for bunghole approx. 35 mm (1.34") diameter Version RS (rust and acid proof) with bottom stop
0638163	Suction strainer V2A (screen cage) M15 G1" for all units from the PROFESSIONAL and HERKULES series with direct suction or multi-piece suction line
0652438	Suction strainer V2A (screen cage) M15, M28 x1.5 for all units from the PROFESSIONAL series with one-piece suction line
0498874	Suction strainer Ø = 70 mm (2.76") complete M 20
0160369	Suction strainer Ø = 70 mm (2.76") complete M 50
0608912	Suction strainer Ø = 70 mm (2.76") complete M 70
0160512	Suction strainer Ø = 150 mm (5.9") complete M 20
0162892	Suction strainer Ø = 150 mm (5.9") complete M 30
0162906	Suction strainer Ø = 150 mm (5.9") complete M 50
0162914	Suction strainer Ø = 150 mm (5.9") complete M 70
0160709	Suction strainer Ø = 150 mm (5.9") complete M 20
0162841	Suction strainer Ø = 150 mm (5.9") complete M 30
0162868	Suction strainer Ø = 150 mm (5.9") complete M 50
0608920	Suction strainer Ø = 150 mm (5.9") complete M 70

Fluid sieves



Order No.	Diameter (mm / inches)	Mesh width
0414689	70 / 2.76	M 20
0411892	70 / 2.76	M 50
0461741	70 / 2.76	M 70
0411329	150 / 5.9	M 20
0411337	150 / 5.9	M 30
0411345	150 / 5.9	M 50
0411353	150 / 5.9	M 70

WIWA swivels

Order No.	Description	Connections		for spray guns	Max. pressure (bar / psi)
0064955	Swivel Direct connection to spray gun handle	¼" NPSM	M15X1"	500 D	500 / 7251.5
0065013	Swivel/R Direct connection to spray gun handle	⅜" NPSM	M15X1"	500 D	500 / 7251.5
0061042	Swivel/R	¼" NPSM	¼" NPSF	500 F	500 / 7251.5
0612510	Swivel/R	⅜" NPSM	¼" NPSF	500 F	500 / 7251.5
0647592	Swivel Straight version, galvanized steel	⅜" NPTM	½" NPSM	500 F for PFP	400 / 5801.2
0631300	Swivel Straight version	⅜" M	⅜" FNPT	Extrusion guns	400 / 5801.2

WIWA L-swivels

Order No.	Description	Connections		for spray guns	Max. pressure (bar / psi)
0633212	L-swivel	¼" NPSM	¼" NPSF	500 D	500 / 7251.5
0633213	L-swivel Direct connection to spray gun handle	¼" NPSM	M 15x1	500 D	500 / 7251.5

WIWA Z-swivels

Order No.	Description	Connections		for spray guns	Max. pressure (bar / psi)
0633156	Z-swivel	⅜" NPSM	¼" NPSF	500 F	400 / 5801.2
0633158	Z-swivel Direct connection to spray gun handle	¼" NPSM	M 15 x 1	500 D	500 / 7251.5
0631301	Z-swivel	⅜" NPSM	⅜" NPT	Extrusion gun	400

WIWA ball valves

Order No. -N-	Order No. -R-	Description	Connections		Max. pressure (bar / psi)
0630960	0630982	Ball valve HP, complete	¼" swivel nut	¼" NPSM	500 / 7251.5
0630961	0630981	Ball valve HP, complete	⅜" swivel nut	⅜" NPSM	500 / 7251.5
0647195	0646988	Ball valve HP	G ¼"	G ¼"	500 / 7251.5
0647196	0647040	Ball valve HP	G ⅜"	G ⅜"	500 / 7251.5
0630289	-	Ball valve HP	G ½"	G ½"	500 / 7251.5

WIWA material pressure regulator



WIWA material pressure regulator

Order No.	Description	Connections		Max. pressure (bar / psi)
0647130	Material pressure regulator	3/8" NPSM	3/8" NPSM	400 / 5801.2
0647131	Material pressure regulator	1/4" NPSM	1/4" NPSM	400 / 5801.2
0647132	Material pressure regulator	3/8" NPSM	1/4" NPSM	400 / 5801.2
0647133	Material pressure regulator	3/8" NPSM	3/8" NPSM	400 / 5801.2
0643777	Material press. regulator V2A	G 3/8"	G 3/8"	400 / 5801.2
0651611	Material pressure regulator, complete with pressure gauge	G 3/8"	G 1/4"	400 / 5801.2
0651612	Material pressure regulator, complete with pressure gauge	G 3/8"	G 1/4"	250 / 3625.7
0651613	Material pressure regulator, complete with pressure gauge	G 3/8"	G 1/4"	100 / 1450.3

WIWA back pressure regulator



WIWA back pressure regulator

Order No.	Description	Connections		Max. pressure (bar / psi)
0643778	Back pressure regulator	G 3/8"	G 3/8"	400 / 5801.2

Material pressure regulator springs for different pressures

WIWA material pressure regulator spring,
Order No. 0644029

Order No.	Description
0644028	for max. 100 bar (1450.3 psi) set pressure
0644029	for max. 250 bar (3625.7 psi) set pressure
0644030	for max. 400 bar (5801.2 psi) set pressure

WIWA safety rupture discs



WIWA safety rupture disc, Order No. 0643492

Order No.	Colour	Rupture pressure (bar / psi)
0646741	purple	100 / 1450.3
0634849	orange	250 / 3625.7
0648012	black	300 / 4350.9
0640237	brown	500 / 7251.5
0643492	beige	650 / 9426.9
0632752	white	800 / 11602.4

WIWA manifolds



Order No.	N/R/RS	Connections	
0639123	RS	Swivel nut 1x 1/4" NPSM	Nipples 2x 1/4" NPT
0163430	R	Nipple 1x 1/4" NPSF	Nipples 2x 1/4" NPSF
0630523	RS	Nipple 1x 1/4" NPT	Nipples 2x 1/4" NPT
0632355	RS	Swivel nut 1x 3/8" NPSM	Nipples 2x 3/8" NPSF (90°)
0633964	RS	Swivel nut 1x 3/8" NPSM	Nipples 2x 3/8" NPSF (120°)
0638457	RS	Swivel nut 1x 3/8" NPSM	Nipples 3x 3/8" NPSF
0639830	RS	Swivel nut 1x G 1/2"	Nipples 3x 3/8" NPSF
0643609	RS	Swivel nut 1x G 1/2"	Nipples 2x G 1/2"

WIWA wall brackets



Order No.	for unit
0644947	WIWA PROFIT
0619728	WIWA PHOENIX
0064882	WIWA PROFESSIONAL
0643157	WIWA HERKULES
0619728	WIWA material flow heater 3500 HD
0634526	WIWA material flow heater 3500 ND
0639066	WIWA low pressure pump 150.03,5 and 150.05,5
0639067	WIWA low pressure pump 150.08,0 to 600.12
0411264	WIWA transfer pump DA 2:1 and 4:1
0615137	WIWA transfer pump DA 7:1 and 10:1

WIWA static mixer made of plastic with bell and sleeve



WIWA static mixer, Order No. 0651041

Order No.	Nominal width (mm / inches)	Length (mm / inches)	Number of elements	Pressure (bar / psi)
0648434	8 / 0.31	296 / 11.65	32	23 / 333.5
0651041	16.8 / 0.66	295 / 11.61	24	19 / 275.6
0650928	16.8 / 0.66	423 / 17.0	36	19 / 275.6
0654055	20 / 0.79	432 / 17.0	23	39 / 565.6

Accessories for static mixers made of plastic



Protective tube, Order No.: 0650927

Swivel nut for static mixer 0648434
Order-no. 0654205

Order No.	Description	Thread
0650927	Protective tube for static mixer 0650928	7/8" – 14 UNF
0651042	Protective tube for static mixer 0651041	7/8" – 14 UNF
0654205	Swivel nut for static mixer 0648434	7/8" – 14 UNF
0652430	Swivel nut for static mixers 0651041 + 0650922	7/8" – 14 UNF

WIWA static mixers



WIWA static mixer, Order No. 0646503

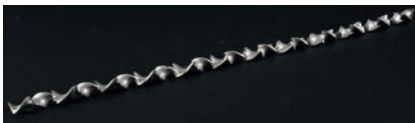

WIWA mixing elements, Order No. 0643612

Order No.	Description	Nominal size (mm/inches)	Connections		Length (mm/inches)	Number of elements	Pressure (bar/psi)
0646503	Sz. 0	8 / 0.31	3/8" NPSM	G 1/2"	366 / 14.4	30	400 / 5801.2
0643611	Sz. I	10 / 0.39	3/8" NPSM	G 1/2"	366 / 14.4	24	400 / 5801.2
0642763	Sz. II	12 / 0.47	3/8" NPSM	G 1/2"	440 / 17.32	24	400 / 5801.2
0647124	Sz. III	20 / 0.79	1/2" NPT	3/4" NPT	375 / 14.76	12	400 / 5801.2



G = BSP thread (straight) R = BSP thread (conical) NPSM = cylindrical pipe thread

WIWA mixing elements



WIWA fibre-reinforced mixing element,
Order No. 0648244

Order No.	Description	Diameter (mm / inches)	Length (mm / inches)	Number of elements
0646504	for static mixer 0646503	8 / 0.31	365 / 14.37	30
0643612	for static mixer 0643611	10 / 0.39	366 / 14.4	24
0649028	for static mixer 0642763	12 / 0.47	440 / 17.32	24
0647134	for static mixer 0647124	20 / 0.79	360 / 14.17	12
0648244	Fibre-reinforced mixing element	9.35 / 0.37	9.7 / 0.38	-

WIWA air maintenance units



Order No.	Item	Connection	for series
0648247	Air maintenance units, complete	G 1/2"	PHOENIX
0648096	Air maintenance units, complete	G 1"	PROFESSIONAL
0648095	Air maintenance units, complete	G 1"	HERKULES
0648257	Air Combi air maintenance units	1/2"	PHOENIX

Air pressure regulator



Air pressure regulator with shut-off ball valve
Order-no. 0060615

Order No.	Item	Connection	for series
0060615	Air pressure regulator with shut-off ball valve, complete	G 1/4"	Feed pumps PHOENIX
0644180	Air pressure regulator with shut-off ball valve, complete	G 1/4"	PROFIT
0634979	Dual air pressure regulator for Air Combi with shut-off ball valve, complete	G 1/4"	PROFIT



Air pressure regulator with brass lever
Order-no. 0634979

WIWA pressure gauges



Order No.	Description	Diameter (mm / inches)	Connection	Pressure range (bar / psi)
0644050	Metal pressure gauge, vertical	40 / 1.57	G 1/8"	0 - 10 / 0 - 145*
0647009	Metal pressure gauge, vertical	40 / 1.57	G 1/4"	0 - 10 / 0 - 145*
0602485	Metal pressure gauge, vertical	50 / 1.97	G 1/4"	0 - 16 / 0 - 232*
0631607	Metal pressure gauge, back wall	40 / 1.57	G 1/8"	0 - 10 / 0 - 145*
0638002	Metal pressure gauge, back wall	40 / 1.57	G 1/4"	0 - 10 / 0 - 14*
0643304	V2A pressure gauge, back wall	50 / 1.97	G 1/4"	0 - 10 / 0 - 145*
0631359	Matt black pressure gauge, glycerine filled, vertical	63 / 2.48	G 1/4"	0 - 400 / 0 - 5801.2
0644061	V2A pressure gauge, glycerine filled, vertical	63 / 2.48	G 1/4"	0 - 400 / 0 - 5801.2*
0633848	V2A pressure gauge, glycerine filled, vertical	63 / 2.48	G 1/4"	0 - 600 / 0 - 8701.8*
0646947	V2A press. gauge with press. mediator, back wall, glycerine filled	63 / 2.48	G 1/2"	0 - 160 / 0 - 2320.4
0630577	V2A press. gauge with press. mediator, back wall, glycerine filled	63 / 2.48	G 1/2"	0 - 600 / 0 - 8701.8

WIWA pressure gauge, complete, diameter 63 mm (2.48")

Order No.	Description	Connections		Pressure range (bar / psi)
		Retaining nut	Nipple	
0648438	Pressure gauge for material outlet with non-return valve	M 22x1.5	M 22x1.5	0 - 400 / 0 - 5801.2
0648439	Pressure gauge for material outlet without non-return valve	M 22x1.5	M 22x1.5	0 - 400 / 0 - 5801.2
0648168	Pressure gauge for material outlet without non-return valve	G 1/2"	G 1/2"	0 - 400 / 0 - 5801.2
0648169	Pressure gauge for material outlet without non-return valve	G 1/2"	G 1/2"	0 - 600 / 0 - 8701.8

WIWA 2K contact pressure gauge



Pneumatic signal, Order No.: 0644577

Order No.	Description	Diameter (mm / inches)	Connection	Pressure range (bar / psi)
0644575	pneumatic signals	100 / 3.94	G 3/4"	0 - 100 / 0 - 1450.3*
0646615	pneumatic signals	100 / 3.94	G 3/4"	0 - 250 / 0 - 3625.7*
0644576	pneumatic signals	100 / 3.94	G 3/4"	0 - 400 / 0 - 5801.2*
0644577	pneumatic signals	100 / 3.94	G 3/4"	0 - 800 / 0 - 11602.4*
0649486	electrical signals	100 / 3.94	G 3/4"	0 - 400 / 0 - 5801.2*
0649691	electrical signals	100 / 3.94	G 3/4"	0 - 800 / 0 - 11602.4*



* The pressure gauge indicates the pressure both in bar and in PSI.

4 WIWA heating systems and accessories

- 4.1 WIWA fluid heaters
- 4.2 WIWA wall brackets
- 4.3 WIWA hot spray mounting kits for WIWA Airless paint spraying equipment
WIWA drum floor heater
- 4.4 WIWA drum heating band
WIWA material heater

WIWA material flow heaters

WIWA low pressure and high pressure material flow heaters for heating coating materials to the desired processing temperature. Some material flow heaters are explosion-proof; the heater parts that conduct material are made from stainless steel.



Order No.	Description	Explosion-proof	Voltage (Volt)	Output (Watt)	Max. pressure (bar / psi)
On request	WIWA 2000 HD	no	110	2000	450 / 6526.3
0614335	WIWA 3500 HD	EX 2 2G	230	3500	450 / 6526.3
0648374	WIWA 3500 HD	EX 2 2G	400	3500	450 / 6526.3
0648376	WIWA 3500 HD	no	440	3500	450 / 6526.3
0639850	WIWA 3500 HD	EX 2 2G	3x 230	3500	450 / 6526.3
0633599	WIWA 3500 ND	EX 2 2G	230	3500	200 / 2900.6
0649584	WIWA 3500 ND suitable for foodstuffs	EX 2 2G	230	3500	200 / 2900.6
0648375	WIWA 3500 ND	EX 2 2G	400	3500	200 / 2900.6
0648377	WIWA 3500 ND	no	440	3500	200 / 2900.6
0650081	WIWA 3500 ND	EX 2 2G	3x 230	3500	200 / 2900.6
0619728	Wall bracket for high pressure (HD) heater				
0634526	Wall bracket for low pressure (ND) heater				
0620661	Temperature indicator (only for high pressure (HD) material flow heaters)				
0649463	Temperature indicator (only for low pressure (ND) material flow heaters)				
0632538	Carrier base for WIWA 3500 HD				
0633869	Carrier base for WIWA 3500 ND				
0632538	Mounting kit high pressure (HD) material flow heater onto carrier base -N-				
0639788	Mounting kit high pressure (HD) material flow heater onto carrier base -RS-				

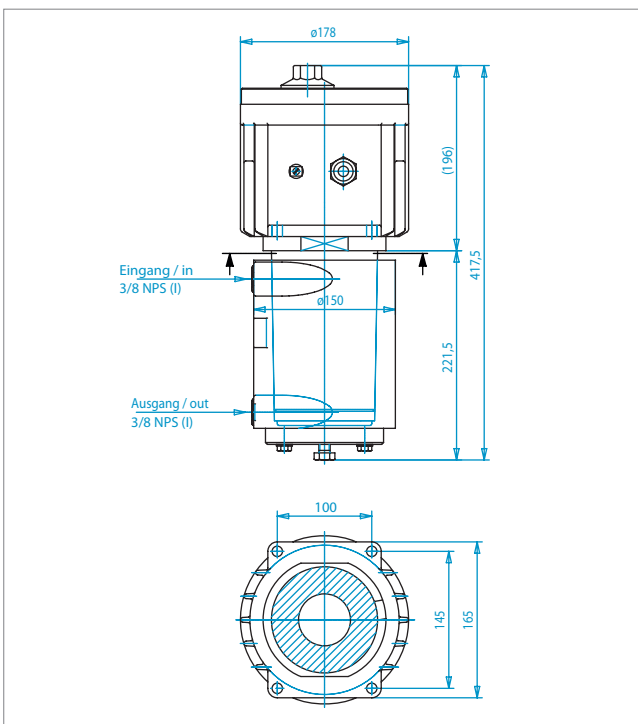

Material flow heater 3500HD, Order No. 0614335

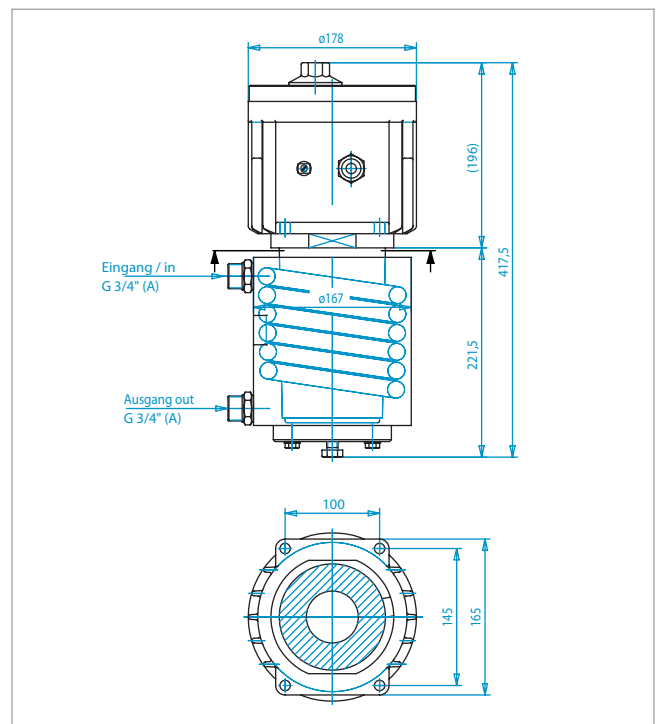

Material flow heater 3500ND, Order No. 0648375

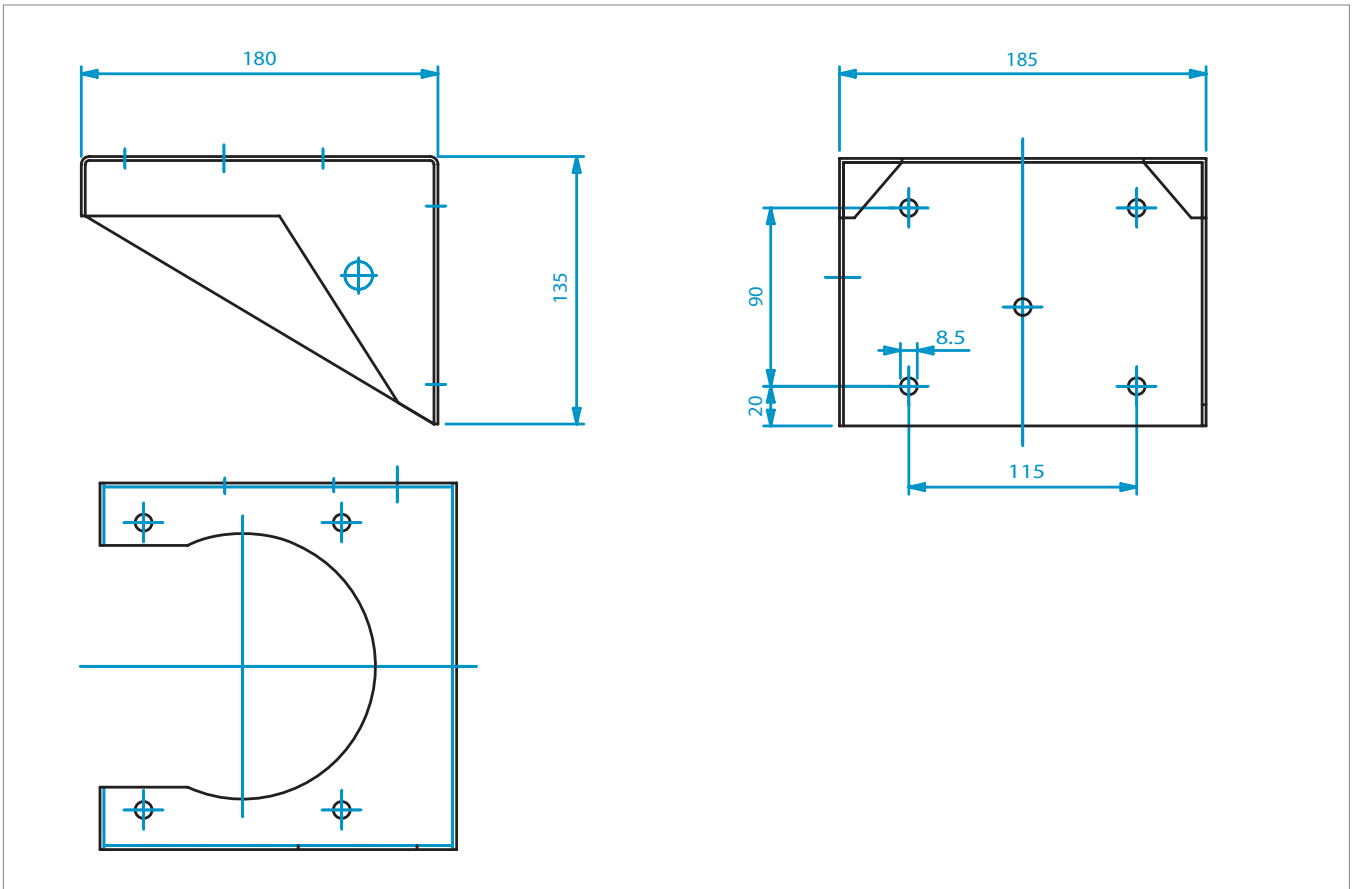

WIWA wall brackets for LM Ø105 and Ø140, Order No. 0619728

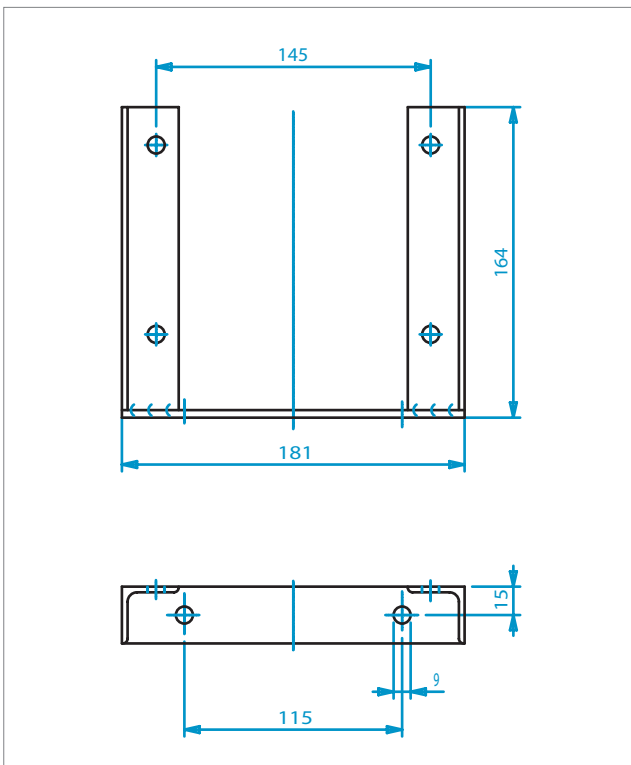

WIWA bracket for material flow heater, Order No. 0634526

Hot spray unit mounting kits for WIWA Airless paint spraying equipment

Model	Order numbers			
	on cart (F)		on wall bracket (W)	
	with circulation	without circulation	with circulation	without circulation
10066	0625442	0630498	0630531	0630525
15042	0625442	0630498	0630531	0630525
24053	0629398	0630498	0630531	0630525
24071	0629398	0630498	0630531	0630525
28048	0629398	0630498	0630531	0630525
28064	0629398	0630498	0630531	0630525
38032	0640078	0640926	0640928	0640929
38042	0640078	0640926	0640928	0640929
44024	0640078	0640926	0640928	0640929
44032	0640078	0640926	0640928	0640929
35061	0642237	0642238	-	-
35075	0642215	0642222	-	-
48046	0642215	0642222	-	-
48057	0642237	0642238	-	-



The scope of delivery includes the WIWA3500 material flow heater with back pressure regulator, temperature indicator and all necessary connection hoses and attachments. Other attachment sets for the hot spray unit available on request.

WIWA drum floor heaters

WIWA drum floor heater for heating coating materials in 200 litre (52.83 US gal) drums. Heating the material through the drum floor is particularly beneficial, because the material is heated exactly where it is withdrawn.



Order No.	Description	Ø (mm / inches)	Height (mm / inches)	Voltage (V)	Output (W)
0638501	Floor heater type B0-200 · with regulator (50 – 200 °C, 122 – 392 °F) · connecting cable 1.5 m (4.92 ft) · weight approx. 15 kg (33 lb)	550 / 21.65	80 / 3.15	230	1500
0644768	Floor heater type B0-200 · with regulator (50 – 200 °C, 122 – 392 °F) · connecting cable 1.5 m (4.92 ft.) long · weight approx. 15 kg (33 lb)	550 / 21.65	80 / 3.15	400	1500
0639158	Floor heater type B0-200 X · with regulator (4 – 163 °C, 39.2 – 325.4 °F) · ATEX-EX II 2 GD EEX e ia m II C T4	570 / 22.44	75 / 2.95	230	1170

WIWA drum heating belt

Drum heating belt is fitted around 200 litre (52.83 US gal) drums and warms the material. Depending on the desired material temperature one or several heating belts may be required. Other models can be supplied on request.



Order No.	Description	Ø (mm / inches)	Width (mm / inches)	Voltage (Volt)	Output (Watt)
0638508	Drum heating belt 180 °C (356 °F): · with thermostat · fixture with hook and springs · connecting cable 1.5 m (4.92 ft) without plug · with earth conductor	570 / 22.44	75 / 2.95	230	1000
0644062	Drum heating band 180 °C (356 °F): · with thermostat · fixture with hook and springs · connecting cable 1.5 m (4.92 ft) without plug · with ground conductor	570 / 22.44	75 / 2.95	115	1000
0642098	Drum heating belt for 20 l (5.28 US gal) container 180 °C (356 °F)	290 / 11.42	75 / 2.95	230	300

WIWA material heater



Order No.	Description	Voltage (Volt)	Output (Watt)
0650540	Insertion depth: 690 mm (27.16 inches) Insulation class: IP 57	230	2300

5 WIWA transfer pumps

- 5.1 WIWA low pressure pumps with spring tensioned packing
Version: V-rings
Series 150, 375, 600
- 5.2 WIWA low pressure pumps with adjustable packing
Version: V-rings
Series 150, 375, 600
- 5.3 WIWA low pressure pumps with spring tensioned U-seals
Series 150, 375, 600
- 5.5 WIWA low pressure pumps
Series Rapid 200.01, 100.02
- 5.6 WIWA oil transfer pumps
Series 40, 82
- 5.7 WIWA transfer pumps for water
Series 75, 150
- 5.8 WIWA DA-pumps
- 5.9 WIWA thick film/mortar pumps
410.09, 600.12

WIWA low pressure pumps

With spring tensioned packing. Version: V-packing rings



WIWA low pressure pump 150.03.5 N-L



WIWA low pressure pump 375.03 R



WIWA low pressure pump 600.06 R

Order No.	Unit type	Version	Pressure ratio	Max. air inlet pressure (bar / psi)	Max. operating pressure (bar / psi)	Weight (kg / lbs) approx.	Dimensions (mm / inches) approx.
-----------	-----------	---------	----------------	-------------------------------------	-------------------------------------	---------------------------	----------------------------------

Series 150 (pump output per cycle: 150 cm³ / 9.15 in³)

0641562	150.03.5	N	3.5:1	8 / 116	28 / 406	14.0 / 30.86	ø 120 x 700 / ø 47.24 x 275.59
0641564	150.03.5	N-L	3.5:1	8 / 116	28 / 406	17.5 / 38.58	ø 120 x 1330 / ø 47.24 x 523.62
0641563	150.03.5	R	3.5:1	8 / 116	28 / 406	14.0 / 30.86	ø 120 x 700 / ø 47.24 x 275.59
0641565	150.03.5	R-L	3.5:1	8 / 116	28 / 406	17.5 / 38.58	ø 120 x 1330 / ø 47.24 x 523.62
0641566	150.05.5	N	5.5:1	8 / 116	44 / 638.1	14.0 / 30.86	ø 120 x 700 / ø 47.24 x 275.59
0641568	150.05.5	N-L	5.5:1	8 / 116	44 / 638.1	17.5 / 38.58	ø 120 x 1330 / ø 47.24 x 523.62
0641567	150.05.5	R	5.5:1	8 / 116	44 / 638.1	14.0 / 30.86	ø 120 x 700 / ø 47.24 x 275.59
0641569	150.05.5	R-L	5.5:1	8 / 116	44 / 638.1	17.5 / 38.58	ø 120 x 1330 / ø 47.24 x 523.62
0641570	150.08	N	8:1	8 / 116	64 / 928.2	14.5 / 31.97	ø 200 x 794 / ø 78.74 x 312.60
0641572	150.08	N-L	8:1	8 / 116	64 / 928.2	17.5 / 38.58	ø 200 x 1425 / ø 78.74 x 561.02
0641571	150.08	R	8:1	8 / 116	64 / 928.2	14.5 / 31.97	ø 200 x 794 / ø 78.74 x 312.60
0641573	150.08	R-L	8:1	8 / 116	64 / 928.2	17.5 / 38.58	ø 200 x 1425 / ø 78.74 x 561.02
0643919	150.15.5	N	15.5:1	6 / 87	93 / 1348.8	19.0 / 41.9	ø 200 x 794 / ø 78.74 x 312.60
0643921	150.15.5	N-L	15.5:1	6 / 87	93 / 1348.8	22.0 / 48.5	ø 200 x 1425 / ø 78.74 x 561.02
0643918	150.15.5	R	15.5:1	6 / 87	93 / 1348.8	19.0 / 41.9	ø 200 x 794 / ø 78.74 x 312.60
0643920	150.15.5	R-L	15.5:1	6 / 87	93 / 1348.8	22.0 / 48.5	ø 200 x 1425 / ø 78.74 x 561.02

Series 375 (pump output per cycle: 375 cm³ / 22.88 in³)

0641574	375.03	N	3:1	8 / 116	24 / 348	27.0 / 59.52	ø 160 x 941 / ø 62.99 x 370.47
0641575	375.03	R	3:1	8 / 116	24 / 348	27.0 / 59.52	ø 160 x 941 / ø 62.99 x 370.47
0648496	375.03	N-L	3:1	8 / 116	24 / 348	32.0 / 70.55	ø 160 x 1513 / ø 62.99 x 595.67
0641576	375.05	N	5:1	8 / 116	40 / 580.1	27.0 / 59.52	ø 200 x 941 / ø 78.74 x 370.47
0641577	375.05	R	5:1	8 / 116	40 / 580.1	27.0 / 59.52	ø 200 x 941 / ø 78.74 x 370.47
0648497	375.05	N-L	5:1	8 / 116	40 / 580.1	32.0 / 70.55	ø 200 x 1513 / ø 78.74 x 595.67
0641578	375.09.5	N	9.5:1	8 / 116	76 / 1102.2	35.5 / 78.26	ø 200 x 941 / ø 78.74 x 370.47
0641579	375.09.5	R	9.5:1	8 / 116	76 / 1102.2	35.5 / 78.26	ø 200 x 941 / ø 78.74 x 370.47
0648498	375.09.5	N-L	9.5:1	8 / 116	76 / 1102.2	39.0 / 85.98	ø 200 x 941 / ø 78.74 x 370.47
0646312	375.19	N	19:1	8 / 116	152 / 2204.4	35.5 / 78.26	ø 314 x 1098 / ø 123.62 x 432.28

Series 600 (pump output per cycle: 600 cm³ / 36.61 in³)

0641580	600.03	N	3:1	8 / 116	24 / 348	33.0 / 72.75	ø 160 x 945 / ø 62.99 x 372
0641581	600.03	R	3:1	8 / 116	24 / 348	33.0 / 72.75	ø 160 x 945 / ø 62.99 x 372
0641582	600.06	N	6:1	8 / 116	48 / 696.1	33.5 / 73.85	ø 200 x 945 / ø 78.74 x 372
0641583	600.06	R	6:1	8 / 116	48 / 696.1	33.5 / 73.85	ø 200 x 945 / ø 78.74 x 372
0641584	600.12	N	12:1	8 / 116	84 / 1218.2	-	ø 314 x 1101 / ø 123.62 x 433.46
0641585	600.12	R	12:1	8 / 116	84 / 1218.2	-	ø 314 x 1101 / ø 123.62 x 433.46



Available models:

- N = standard version (normal steel) - short
- N-L = standard version (normal steel) - long (for 200 l (52.83 US gal) drum and standpipe)
- RS = rust and acid proof version - short
- RS-L = rust and acid proof version - long (for 200 l (52.83 US gal) drum and standpipe)

WIWA low pressure pumps

With adjustable packing. Version: V-packing rings



WIWA low pressure pump 150.03.5 N-L



WIWA low pressure pump 375.03 R



WIWA low pressure pump 600.06 R

Order No.	Unit type	Version	Pressure ratio	Max. air inlet pressure (bar / psi)	Max. operating pressure (bar / psi)	Weight (kg / lbs) approx.	Dimensions (mm / inches) approx.
-----------	-----------	---------	----------------	-------------------------------------	-------------------------------------	---------------------------	----------------------------------

Series 150 (pump output per cycle: 150 cm³ / 9.15 in³)

0639026	150.03.5	N	3.5:1	8 / 116	28 / 406	14 / 30.86	ø 120 x 700 / ø 4.72 x 27.56
0639031	150.03.5	N-L	3.5:1	8 / 116	28 / 406	17.5 / 38.58	ø 120 x 1330 / ø 4.72 x 52.36
0639028	150.03.5	R	3.5:1	8 / 116	28 / 406	14 / 30.86	ø 120 x 700 / ø 4.72 x 27.56
0639034	150.03.5	R-L	3.5:1	8 / 116	28 / 406	17.5 / 38.58	ø 120 x 1330 / ø 4.72 x 52.36
0638927	150.05.5	N	5.5:1	8 / 116	44 / 638.1	14 / 30.86	ø 120 x 700 / ø 4.72 x 27.55
0639032	150.05.5	N-L	5.5:1	8 / 116	44 / 638.1	17.5 / 38.58	ø 120 x 1330 / ø 4.72 x 52.36
0639029	150.05.5	R	5.5:1	8 / 116	44 / 638.1	14 / 30.86	ø 120 x 700 / ø 4.72 x 27.55
0639035	150.05.5	R-L	5.5:1	8 / 116	44 / 638.1	17.5 / 38.58	ø 120 x 1330 / ø 4.72 x 52.36
0639027	150.08	N	8:1	8 / 116	64 / 928.2	14.5 / 31.97	ø 200 x 794 / ø 7.87 x 31.26
0639033	150.08	N-L	8:1	8 / 116	64 / 928.2	17.5 / 38.58	ø 200 x 1425 / ø 7.87 x 56.10
0639030	150.08	R	8:1	8 / 116	64 / 928.2	14.5 / 31.97	ø 200 x 794 / ø 7.87 x 31.26
0639036	150.08	R-L	8:1	8 / 116	64 / 928.2	17.5 / 38.58	ø 200 x 1425 / ø 7.87 x 56.10

Series 375 (pump output per cycle: 375 cm³ / 22.88 in³)

0639038	375.03	N	3:1	8 / 116	24 / 348	-	ø 160 x 941 / ø 6.3 x 37.05
0639041	375.03	R	3:1	8 / 116	24 / 348	-	ø 160 x 941 / ø 6.3 x 37.05
** 0648496	375.03	N-L	3:1	8 / 116	24 / 348	-	ø 160 x 1513.5 / ø 6.3 x 59.59
0639039	375.05	N	5:1	8 / 116	40 / 580.1	27.0 / 59.52	ø 200 x 941 / ø 7.87 x 37.05
0639042	375.05	R	5:1	8 / 116	40 / 580.1	27.0 / 59.52	ø 200 x 941 / ø 7.87 x 37.05
** 0648497	375.05	N-L	5:1	8 / 116	40 / 580.1	27.0 / 59.52	ø 200 x 1513.5 / ø 7.87 x 59.59
0639040	375.09.5	N	9.5:1	8 / 116	76 / 1102.2	35.5 / 78.26	ø 200 x 941 / ø 7.87 x 37.05
0639043	375.09.5	R	9.5:1	8 / 116	76 / 1102.2	35.5 / 78.26	ø 200 x 941 / ø 7.87 x 37.05
** 0648498	375.09.5	N-L	9.5:1	8 / 116	76 / 1102.2	35.5 / 78.26	ø 200 x 1513.5 / ø 7.87 x 59.59

Series 600 (pump output per cycle: 600 cm³ / 36.61 in³)

0639044	600.03	N	3:1	8 / 116	24 / 348	-	ø 160 x 945 / ø 6.3 x 37.2
0639045	600.03	R	3:1	8 / 116	24 / 348	-	ø 160 x 945 / ø 6.3 x 37.2
0638924	600.06	N	6:1	8 / 116	48 / 696.1	33.5 / 73.85	ø 200 x 945 / ø 7.87 x 37.2
0639046	600.06	R	6:1	8 / 116	48 / 696.1	33.5 / 73.85	ø 200 x 945 / ø 7.87 x 37.2
0639056	600.12	N	12:1	8 / 116	84 / 1218.2	-	ø 314 x 1101 / ø 12.36 x 43.35
0639055	600.12	R	12:1	8 / 116	84 / 1218.2	-	ø 314 x 1101 / ø 12.36 x 43.35



Available models:

- N = standard version (normal steel) - short
 - N-L = standard version (normal steel) - long (for 216 l (57.06 US gal) drum and standpipe)
 - RS = rust and acid proof version - short
 - RS-L = rust and acid proof version - long (for 216 l (57.06 US gal) drum and standpipe)
- ** with spring tensioned packing

WIWA low pressure pumps

with spring tensioned U-seals



WIWA low pressure pump 150.03.5 N-L



WIWA low pressure pump 375.03 R



WIWA low pressure pump 600.06 R

Order No.	Unit type	Version	Pressure ratio	Max. air inlet pressure (bar / psi)	Max. operating pressure (bar / psi)	Weight (kg / lbs) approx.	Dimensions (mm / inches) approx.
-----------	-----------	---------	----------------	-------------------------------------	-------------------------------------	---------------------------	----------------------------------

Series 150 (pump output per cycle: 150 cm³ / 9.15 in³)

0643052	150.03.5	N	3.5:1	8 / 116	28 / 406	14 / 30.86	ø 120 x 700 / ø 4.72 x 27.56
0643054	150.03.5	N-L	3.5:1	8 / 116	28 / 406	17.5 / 38.58	ø 120 x 1330 / ø 4.72 x 52.36
0643053	150.03.5	R	3.5:1	8 / 116	28 / 406	14 / 30.86	ø 120 x 700 / ø 4.72 x 27.56
0634055	150.03.5	R-L	3.5:1	8 / 116	28 / 406	17.5 / 38.58	ø 120 x 1330 / ø 4.72 x 52.36
0643056	150.05.5	N	5.5:1	8 / 116	44 / 638.1	14 / 30.86	ø 120 x 700 / ø 4.72 x 27.56
0643058	150.05.5	N-L	5.5:1	8 / 116	44 / 638.1	17.5 / 38.58	ø 120 x 1330 / ø 4.72 x 52.36
0643057	150.05.5	R	5.5:1	8 / 116	44 / 638.1	14 / 30.86	ø 120 x 700 / ø 4.72 x 27.56
0643059	150.05.5	R-L	5.5:1	8 / 116	44 / 638.1	17.5 / 38.58	ø 120 x 1330 / ø 4.72 x 52.36
0643060	150.08	N	8:1	8 / 116	64 / 928.2	14.5 / 31.97	ø 200 x 794 / ø 7.87 x 31.26
0643061	150.08	N-L	8:1	8 / 116	64 / 928.2	17.5 / 38.58	ø 200 x 1425 / ø 7.87 x 56.1
0643034	150.08	R	8:1	8 / 116	64 / 928.2	14.5 / 31.97	ø 200 x 794 / ø 7.87 x 31.26
0643062	150.08	R-L	8:1	8 / 116	64 / 928.2	17.5 / 38.58	ø 200 x 1425 / ø 7.87 x 56.1

Series 375 (pump output per cycle: 375 cm³ / 22.88 in³)

0643063	375.03	N	3:1	8 / 116	24 / 348	-	ø 160 x 941 / ø 6.3 x 37.05
0643064	375.03	R	3:1	8 / 116	24 / 348	-	ø 160 x 941 / ø 6.3 x 37.05
0643065	375.05	N	5:1	8 / 116	40 / 580.1	27.0 / 59.52	ø 200 x 941 / ø 7.87 x 37.05
0643066	375.05	R	5:1	8 / 116	40 / 580.1	27.0 / 59.52	ø 200 x 941 / ø 7.87 x 37.05
0643067	375.09.5	N	9.5:1	8 / 116	76 / 1102.2	35.5 / 78.26	ø 200 x 941 / ø 7.87 x 37.05
0643068	375.09.5	R	9.5:1	8 / 116	76 / 1102.2	35.5 / 78.26	ø 200 x 941 / ø 7.87 x 37.05

Series 600 (pump output per cycle: 600 cm³ / 36.61 in³)

0643069	600.03	N	3:1	8 / 116	24 / 348	-	ø 160 x 945 / ø 6.3 x 37.2
0643070	600.03	R	3:1	8 / 116	24 / 348	-	ø 160 x 945 / ø 6.3 x 37.2
0643071	600.06	N	6:1	8 / 116	48 / 696.1	33.5 / 73.85	ø 200 x 945 / ø 7.87 x 37.2
0643072	600.06	R	6:1	8 / 116	48 / 696.1	33.5 / 73.85	ø 200 x 945 / ø 7.87 x 37.2
0643073	600.12	N	12:1	8 / 116	84 / 1218.2	-	ø 314 x 1101 / ø 12.36 x 43.35
0643074	600.12	R	12:1	8 / 116	84 / 1218.2	-	ø 314 x 1101 / ø 12.36 x 43.35

i

Available models:

- N = standard version (normal steel) - short
- N-L = standard version (normal steel) - long
(for 216 l (57.06 US gal) drum and standpipe)
- RS = rust and acid proof version - short
- RS-L = rust and acid proof version - long
(for 216 l (57.06 US gal) drum and standpipe)

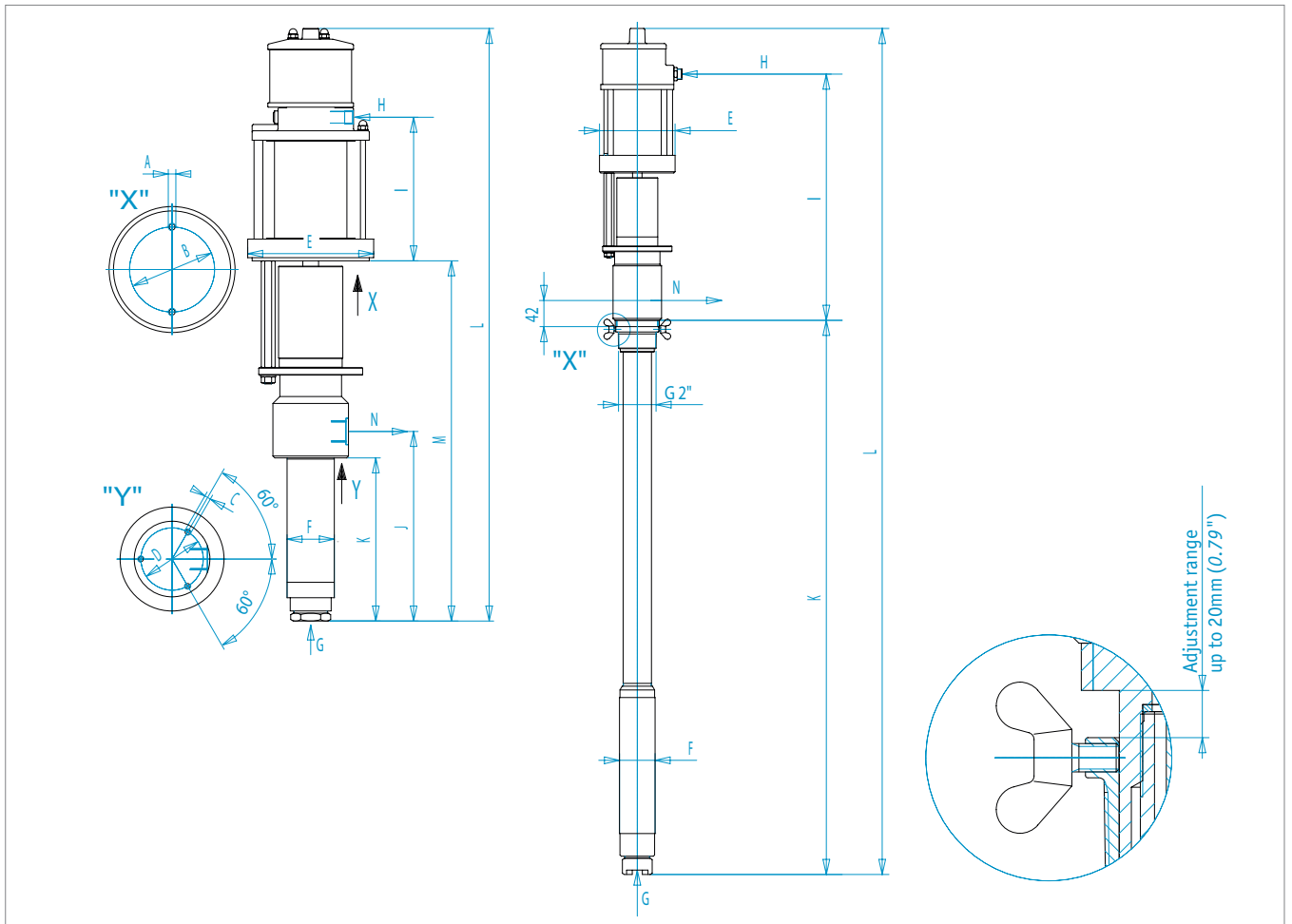

Section lengths and diameter in mm / inch

Model	a	b	c	d	e	f	g	h	i	j	k	l	m	n
150.03.5	M8	90 / 3.54	-	-	120 / 4.72	56.5 / 2.22	G1 1" (f)	3/8" NPT (m)	157 / 6.18	268 / 10.55	236 / 9.29	700 / 27.56	470 / 18.5	G 3/4" (f)
150.05.5	M8	90 / 3.54	-	-	120 / 4.72	56.5 / 2.22	G1 1" (f)	3/8" NPT (m)	157 / 6.18	268 / 10.55	236 / 9.29	700 / 27.56	470 / 18.5	G 3/4" (f)
150.08.0	M12	135 / 5.31	-	-	200 / 7.87	56.5 / 2.22	G1 1" (f)	G 1/2" (f)	183 / 7.2	268 / 10.55	236 / 9.29	794 / 31.26	470 / 18.5	G 3/4" (f)
150.15.5	M12	135 / 5.31	-	-	200 / 7.87	56.5 / 2.22	G1 1" (f)	G 1/2" (f)	183 / 7.2	268 / 10.55	236 / 9.29	794 / 31.26	470 / 18.5	G 3/4" (f)
375.03.0	M12	135 / 5.31	M10	99	160 / 6.3	75 / 2.95	G1 1/2" (f)	G 1/2" (f)	228 / 8.98	301 / 11.85	259 / 10.2	941 / 37.05	572 / 22.52	G 1" (f)
375.05.0	M12	135 / 5.31	M10	99	200 / 7.87	75 / 2.95	G1 1/2" (f)	G 1/2" (f)	228 / 8.98	301 / 11.85	259 / 10.2	941 / 37.05	572 / 22.52	G 1" (f)
375.09.5	M12	135 / 5.31	M10	99	200 / 7.87	75 / 2.95	G1 1/2" (f)	G 1/2" (f)	228 / 8.98	301 / 11.85	259 / 10.2	941 / 37.05	572 / 22.52	G 1" (f)
375.19	M12	135 / 5.31	M10	99	314 / 12.36	75 / 2.95	G1 1/2" (f)	G 1" (f)	305 / 12	301 / 11.85	259 / 10.2	1098 / 43.23	572 / 22.52	G 1" (f)
600.03.0	M12	135 / 5.31	M10	119	200 / 7.87	95 / 3.74	G1 1/2" (f)	G 1/2" (f)	228 / 8.98	305 / 12	261 / 10.27	945 / 37.2	576 / 22.68	G 1" (f)
600.06.0	M12	135 / 5.31	M10	119	200 / 7.87	95 / 3.74	G1 1/2" (f)	G 1/2" (f)	228 / 8.98	305 / 12	261 / 10.27	945 / 37.2	576 / 22.68	G 1" (f)
600.12.0	M12	135 / 5.31	M10	119	314 / 12.36	95 / 3.74	G1 1/2" (f)	G 1" (f)	305 / 12	305 / 12	261 / 10.27	1101 / 43.35	576 / 22.68	G 1" (f)
150.03.5 L	-	-	-	-	120 / 4.72	56.6 / 2.32	-	3/8" NPT (m)	406 / 15.98	-	880 / 34.65	1343 / 52.87	-	G 3/4" (f)
150.05.5 L	-	-	-	-	120 / 4.72	56.6 / 2.23	-	3/8" NPT (m)	406 / 15.98	-	880 / 34.64	1343 / 52.87	-	G 3/4" (f)
150.08.0 L	-	-	-	-	200 / 7.87	56.6 / 2.23	-	G 1/2" (f)	432 / 17	-	880 / 34.64	1438 / 56.61	-	G 3/4" (f)
150.15.5 L	-	-	-	-	200 / 7.87	56.6 / 2.23	-	G 1/2" (f)	432 / 17	-	880 / 34.64	1438 / 56.61	-	G 3/4" (f)
375.03 L	-	-	-	-	160 / 6.3	80 / 3.15	-	G 1/2" (f)	228 / 8.98	-	832 / 32.75	1514 / 59.6	-	G 1" (f)
375.05 L	-	-	-	-	200 / 7.87	80 / 3.15	-	G 1/2" (f)	228 / 8.98	-	832 / 32.75	1514 / 59.6	-	G 1" (f)
375.09 L	-	-	-	-	200 / 7.87	80 / 3.15	-	G 1/2" (f)	228 / 8.98	-	832 / 32.75	1514 / 59.6	-	G 1" (f)

WIWA Rapid series
low pressure pumps
200.01, 100.02

WIWA Rapid series low pressure pumps for loss-free filling and pumping of all kinds of fluids. Pumped material: emulsions, emulsion paints, oils, stains, paints, solvents, insecticides, liquid chemicals, cutting oils, separating oils.

Order No.	Unit type	Version	Pressure ratio	Max. air inlet pressure (bar / psi)	Max. operating pressure (bar / psi)	Material outlet	Material inlet	Air inlet	Weight (kg / lbs) approx.	Dimensions (mm / inches) approx.
-----------	-----------	---------	----------------	-------------------------------------	-------------------------------------	-----------------	----------------	-----------	---------------------------	----------------------------------

Series 200.01 (pump output per cycle: 200 cm³ / 12.2 in³)

0487899	200.01-K	N	1:1	8 / 116	10 / 145	¾" NPT(f)	DA*	⅜" NPT(m)	5 / 11	ø 80 x 777 / ø 3.15 x 30.59
0488151	200.01-K	N-¾	1:1	8 / 116	10 / 145	¾" NPT(f)	¾" NPT(m)	⅜" NPT(m)	5 / 11	ø 80 x 784 / ø 3.15 x 30.87
0487953	200.01 L	N-L	1:1	8 / 116	10 / 145	¾" NPT(f)	DA*	⅜" NPT(m)	7 / 15.4	ø 80 x 1317 / ø 3.15 x 51.85
0487929	200.01-K	R	1:1	8 / 116	10 / 145	¾" NPT(f)	DA*	⅜" NPT(m)	5 / 11	ø 80 x 777 / ø 3.15 x 30.59
0488186	200.01-K	R-¾	1:1	8 / 116	10 / 145	¾" NPT(f)	¾" NPT(m)	⅜" NPT(m)	5 / 11	ø 80 x 784 / ø 3.15 x 30.87
0487945	200.01 L	R-L	1:1	8 / 116	10 / 145	¾" NPT(f)	DA*	⅜" NPT(m)	7 / 15.4	ø 80 x 1317 / ø 3.15 x 51.85

Series 100.02 (pump output per cycle: 100 cm³ / 6.1 in³)

0488569	100.02-K	N	2:1	8 / 116	10 / 145	⅜" NPT(f)	DA*	⅜" NPT(m)	4 / 8.81	ø 80 x 773 / ø 3.15 x 30.43
0490229	100.02-K	N-¾	2:1	8 / 116	10 / 145	⅜" NPT(f)	¾" NPT(m)	⅜" NPT(m)	4 / 8.81	ø 80 x 780 / ø 3.15 x 30.7
0487422	100.02 L	N-L	2:1	8 / 116	10 / 145	⅜" NPT(f)	DA*	⅜" NPT(m)	6.5 / 14.33	ø 80 x 1317 / ø 3.15 x 51.85
0488607	100.02-K	R	2:1	8 / 116	10 / 145	⅜" NPT(f)	DA*	⅜" NPT(m)	4 / 8.81	ø 80 x 773 / ø 3.15 x 30.43
0490237	100.02-K	R-¾	2:1	8 / 116	10 / 145	⅜" NPT(f)	¾" NPT(m)	⅜" NPT(m)	4 / 8.81	ø 80 x 780 / ø 3.15 x 30.7
0487503	100.02 L	R-L	2:1	8 / 116	10 / 145	⅜" NPT(f)	DA*	⅜" NPT(m)	6.5 / 14.33	ø 80 x 1317 / ø 3.15 x 51.85

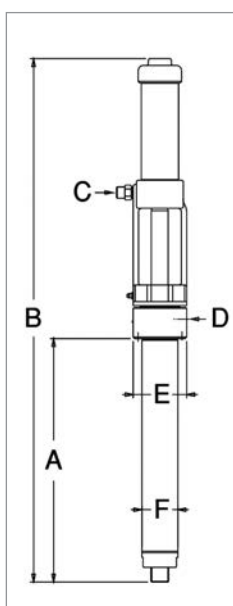

Section lengths and diameters in mm / inch

Model	A	B	C	D	E	F	Weight (kg / lbs)
200.01 short	354 / 13.94	773 / 30.43	¾" NPS (m)	⅜" NPT	ø 80 / ø 3.15	ø 55 / ø 1.96	5.0 / 11
200.01 short ¾	361 / 14.21	780 / 30.7	¾" NPS (m)	¾" NPT	ø 80 / ø 3.15	ø 55 / ø 1.96	5.0 / 11
200.01 long	894 / 35.2	1313 / 51.7	¾" NPS (m)	¾" NPT	ø 80 / ø 3.15	ø 55 / ø 1.96	7.0 / 15.43
100.02 short	358 / 14	777 / 30.59	⅜" NPS (m)	⅜" NPT	ø 80 / ø 3.15	ø 40 / ø 1.57	4.0 / 8.82
100.02 short ¾	365 / 14.37	784 / 30.87	⅜" NPS (m)	¾" NPT	ø 80 / ø 3.15	ø 40 / ø 1.57	4.0 / 8.82
100.02 long	898 / 35.35	1317 / 51.85	⅜" NPS (m)	¾" NPT	ø 80 / ø 3.15	ø 40 / ø 1.57	6.5 / 14.33



* without threaded connection

WIWA oil transfer pumps
Series 40, 82

- for containers with 25, 30 or 60 litres (6.6, 7.92 or 15.85 US gal) contents
- for 216 litre (57.06 US gal) drum
- with a 2" bung adaptor
- for transferring oils



WIWA oil transfer pump type 40.04
Order No. 0488151

Order No.	Unit type	Version	Pressure ratio	Max. operating pressure (bar / psf)	Max. operating pressure (bar / psf)	Material outlet	Air inlet	Weight (kg / lbs) approx.	Dimensions (mm / inches) approx.
-----------	-----------	---------	----------------	-------------------------------------	-------------------------------------	-----------------	-----------	---------------------------	----------------------------------

Series 40 (pump output per cycle: 40 cm³ / 2.44 in³)

0656759	40.04	N	4:1	8 / 116	32 / 464	R 1/2" (f)	R 3/8" (m)	7.2 / 15.87	ø 40 x 1175.5 / ø 1.57 x 46.28
0656760	40.06	N	6:1	8 / 116	48 / 696	R 1/2" (f)	R 3/8" (m)	7.2 / 15.87	ø 40 x 1175.5 / ø 1.57 x 46.28

Series 82 (pump output per cycle: 82 cm³ / 5 in³)

0656757	82.02	R	1.6:1	8 / 116	16 / 232	R 1/2" (f)	R 3/8" (m)	8.1 / 17.86	ø 55 x 1181.5 / ø 2.16 x 46.51
0656758	82.03	R	3:1	8 / 116	24 / 348	R 1/2" (f)	R 3/8" (m)	8.1 / 17.86	ø 55 x 1181.5 / ø 2.16 x 46.51

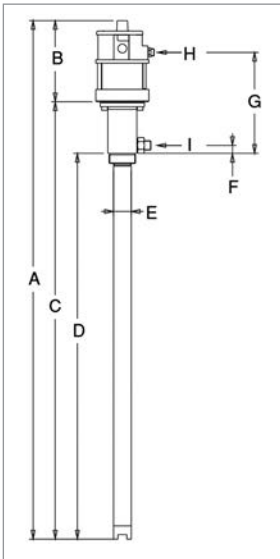

Section lengths and diameters in mm / inches

Model	A	B	C	D	E	F	G	H	I
40.04	1175.5 / 46.28	184.5 / 7.26	991 / 39.01	874 / 34.4	Ø 40 / Ø 1.57	18 / 0.7	229 / 9.01	R 3/8" (m)	R 1/2" (f)
40.06	1175.5 / 46.28	184.5 / 7.26	991 / 39.01	874 / 34.4	Ø 40 / Ø 1.57	18 / 0.7	229 / 9.01	R 3/8" (m)	R 1/2" (f)
82.02	1181.5 / 46.51	184.5 / 7.26	997 / 39.25	880 / 34.64	Ø 55 / Ø 2.16	18 / 0.7	229 / 9.01	R 3/8" (m)	R 1/2" (f)
82.03	1181.5 / 46.51	184.5 / 7.26	997 / 39.25	880 / 34.64	Ø 55 / Ø 2.16	18 / 0.7	229 / 9.01	R 3/8" (m)	R 1/2" (f)

WIWA transfer pumps for water
Series 75, 150

Areas of application: Water transfer for various applications.
For supplying water to blasting units in wet blasting.
Pumped material: Water



WIWA transfer pumps for water
Series 75.04, Order No. 0621811

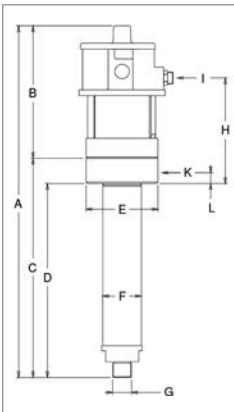

Order No.	Unit type	Version	Pressure ratio	Max. air inlet pressure (bar / psf)	Max. operating pressure (bar / psf)	Material outlet	Material inlet	Air inlet	Weight (kg / lbs) approx.	Dimensions (mm / inches) approx.
-----------	-----------	---------	----------------	-------------------------------------	-------------------------------------	-----------------	----------------	-----------	---------------------------	----------------------------------

Series 75 (pump output per cycle: 75 cm³ / 4.58 in³)

0629442	75.02	R	2:1	8 / 116	16 / 232	1/4" NPS(f)	G 3/4"(m)	3/8" NPT(m)	4.7 / 10.36	ø 120 x 490 / ø 4.72 x 19.29
0621811	75.04	R	4:1	8 / 116	32 / 464	1/4" NPS(f)	G 3/4"(m)	3/8" NPT(m)	4.7 / 10.36	ø 120 x 490 / ø 4.72 x 19.29

Series 150 (pump output per cycle: 150 cm³ / 9.15 in³)

0631115	150.02	R	2:1	8 / 116	16 / 232	1/4" NPS(f)	G 3/4"(m)	3/8" NPT(m)	8.0 / 17.64	ø 120 x 497 / ø 4.72 x 19.29
---------	--------	---	-----	---------	----------	-------------	-----------	-------------	-------------	------------------------------

Model	A	B	C	D	E	F
75.02	489.5 / 19.27	184.5 / 7.26	305 / 12	270 / 10.63	ø 100 / ø 3.94	ø 54 / ø 2.13
75.04	489.5 / 19.27	184.5 / 7.26	305 / 12	270 / 10.63	ø 100 / ø 3.94	ø 54 / ø 2.13
105.02	497 / 19.57	184.5 / 7.26	312.5 / 12.3	277.5 / 10.92	ø 115 / ø 4.52	ø 76 / ø 2.99

Model	G	H	I	K	L
75.02	R 3/4"	147 / 5.79	R 3/4" NPT	R 1/4" NPS	15 / 0.59
75.04	R 3/4"	147 / 5.79	R 3/4" NPT	R 1/4" NPS	15 / 0.59
105.02	R 1"	147 / 5.79	R 3/4" NPT	R 1/4" NPS	15 / 0.59

WIWA DA-pumps

Compressed-air driven WIWA low pressure pumps are ideal for use in paint circulation lines. For the transfer of liquid materials of all viscosities to one or several filling stations as well as for conventional spraying.

Order No.	Unit type	Version	Pressure ratio	output per cycle (cm ³ / in ³)	Max. air inlet pressure (bar / psf)	Max. operating pressure (bar / psf)	Material outlet	Material inlet	Air inlet	Weight (kg / lbs) approx.	Dimensions (mm / inch) approx.
0010537	DA 2:1	N	2:1	165 / 10.07	8 / 116	16 / 232	G ¹ / ₂ "(m)	M25x1(f)	3/8" NPT(m)	1 / 2.2	ø 120 x 447.5 / ø 4.72 x 17.62
0013331	DA 2:1	RS	2:1	165 / 10.07	8 / 116	28 / 406	G ¹ / ₂ "(m)	M25x1(f)	3/8" NPT(m)	-	ø 120 x 447.5 / ø 4.72 x 17.62
0012882	DA 4:1	N	4:1	84 / 5.13	8 / 116	32 / 464	G ³ / ₄ "(f)	M25x1(f)	3/8" NPT(m)	9.7 / 21.38	ø 120 x 528 / ø 4.72 x 20.79
0013358	DA 4:1	RS	4:1	84 / 5.13	8 / 116	32 / 464	G ³ / ₄ "(f)	M25x1(f)	3/8" NPT(m)	9.7 / 21.38	ø 120 x 528 / ø 4.72 x 20.79
0010553	DA 4.5:1	N	4.5:1	288 / 17.57	8 / 116	36 / 522	G ¹ / ₂ "(m)	M25x1(f)	G ¹ / ₂ "(f)	-	ø 151 x 668 / ø 5.94 x 26.3
0013374	DA 4.5:1	RS	4.5:1	288 / 17.57	8 / 116	36 / 522	G ¹ / ₂ "(m)	M25x1(f)	G ¹ / ₂ "(f)	-	ø 151 x 668 / ø 5.94 x 26.3
0010596	DA 7:1	N	7:1	41 / 2.5	8 / 116	56 / 812.2	3/8" NPS(m)	M25x1(f)	3/8" NPT(m)	-	ø 120 x 510 / ø 4.72 x 20.08
0013382	DA 7:1	RS	7:1	41 / 2.5	8 / 116	56 / 812.2	3/8" NPS(m)	M25x1(f)	3/8" NPT(m)	-	ø 120 x 510 / ø 4.72 x 20.08
0010588	DA 9:1	N	9:1	288 / 17.57	6.5 / 94.23	58.5 / 848.4	G ¹ / ₂ "(m)	M25x1(f)	G ¹ / ₂ "(f)	-	ø 186 x 670 / ø 7.32 x 26.38
0013390	DA 9:1	RS	9:1	288 / 17.57	6.5 / 94.23	58.5 / 848.4	G ¹ / ₂ "(m)	M25x1(f)	G ¹ / ₂ "(f)	-	ø 186 x 670 / ø 7.32 x 26.38
0065293	DA 10:1	N	10:1	72 / 4.39	8 / 116	80 / 1160	M22x1.5(m)	M25x1(f)	3/8" NPT(m)	11.8 / 26.01	ø 120 x 645 / ø 4.72 x 25.39

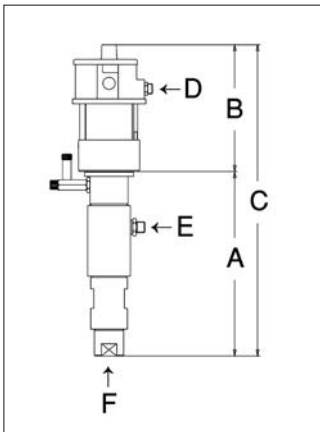

Model	A	B	C	D	E	F
DA 2:1	239 / 9.41	208.5 / 8.21	447.5 / 17.61	3/8" NPS(m)	BSP 1/2" (m)	M25 x 1 (f)
DA 4:1	319.5 / 12.58	208.5 / 8.21	528 / 20.79	3/8" NPS(m)	BSP 1/2" (m)	M25 x 1 (f)
DA 4.5:1	293 / 11.53	375 / 14.76	668 / 26.3	3/8" NPS(m)	BSP 1/2" (m)	M25 x 1 (f)
DA 7:1	302 / 11.89	208.5 / 8.21	510.5 / 20.1	3/8" NPS(m)	3/8" NPS (m)	M25 x 1 (f)
DA 9:1	293 / 11.53	375 / 14.76	668 / 26.3	BSP 1/2" (m)	BSP 1/2" (m)	M25 x 1 (f)
DA 10:1	402 / 15.83	243 / 9.57	645 / 25.39	3/8" NPS(m)	BSP 1/2" (m)	M25 x 1 (f)

WIWA thick film/mortar pumps
410.09, 600.12

- for containers with 25, 30 or 60 litres (6.6, 7.92 or 15.85 US gal) contents
- for 216 litre (57.06 US gal) drum
- with a 2" bung adaptor
- areas of application: ship and ferry decks, concrete and building renovations, sealing cellars, fire protection
- pumped material: epoxy-based and water-based thick films and mortars, e.g. cement mortar, cement-bound fire protection materials, cement grout, filled vinyl esters



Order No.	Unit type	Pressure ratio	Pressure ratio	Max. air inlet pressure (bar / psi)	Max. operating pressure (bar / psi)	Material inlet	Material outlet	Min. recommended compressor performance (l/min / US gal/min)	Air inlet	Weight approx. (kg / lbs)	Dimensions (mm / inches) approx.
-----------	-----------	----------------	----------------	-------------------------------------	-------------------------------------	----------------	-----------------	--	-----------	---------------------------	----------------------------------

Series 410.09 (pump capacity per double stroke: 410 cm³ / 25.02 in³)

0653609	410.09	9:1	4:1	8 / 116	72 / 1044.2	2"	1"	3000 / 792.52	1/2"	95.7 / 210.98	ø 40 x 1175.5 / ø 1.57 x 46.28
---------	--------	-----	-----	---------	-------------	----	----	---------------	------	---------------	--------------------------------

Series 600.12 (pump capacity per double stroke: 600 cm³ / 36.61 in³)

0652595	600.12	12:1	1.6:1	8 / 116	96 / 1392.3	2"	1"	3000 / 792.52	1"	118 / 260.15	ø 55 x 1181.5 / ø 2.16 x 46.51
---------	--------	------	-------	---------	-------------	----	----	---------------	----	--------------	--------------------------------

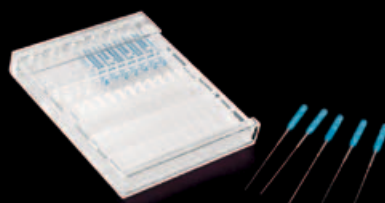

Headquarters and Production

WIWA Wilhelm Wagner GmbH & Co. KG
Gewerbestraße 1-3
35633 Lahnau

Tel. +49(0)64 41/60 9-0
Fax +49(0)64 41/60 9-50

info@wiwa.de
www.wiwa.de
www.wiwa.com

WIWA Partnership USA

WIWA LP
107 N. Main St.
P.O. Box 398, Alger, OH 45812

Phone: +1-419-757-0141
Fax: +1-419-549-5173
Toll Free: +1-855-757-0141

sales@wiwalp.com
www.wiwalp.com

WIWA Subsidiary China

WIWA (Taicang) Co., Ltd.
Building A of Huaxin Industrial Park
No.11 East Qingdao Road, Taicang City
Jiangsu Province 215400, P.R.China

Tel: +86-512-53548857
Fax: +86-512-53548859

info@wiwa-china.com
www.wiwa-china.com